

FIRE DETECTION

S Y S T E M S

a Consultants' Guide

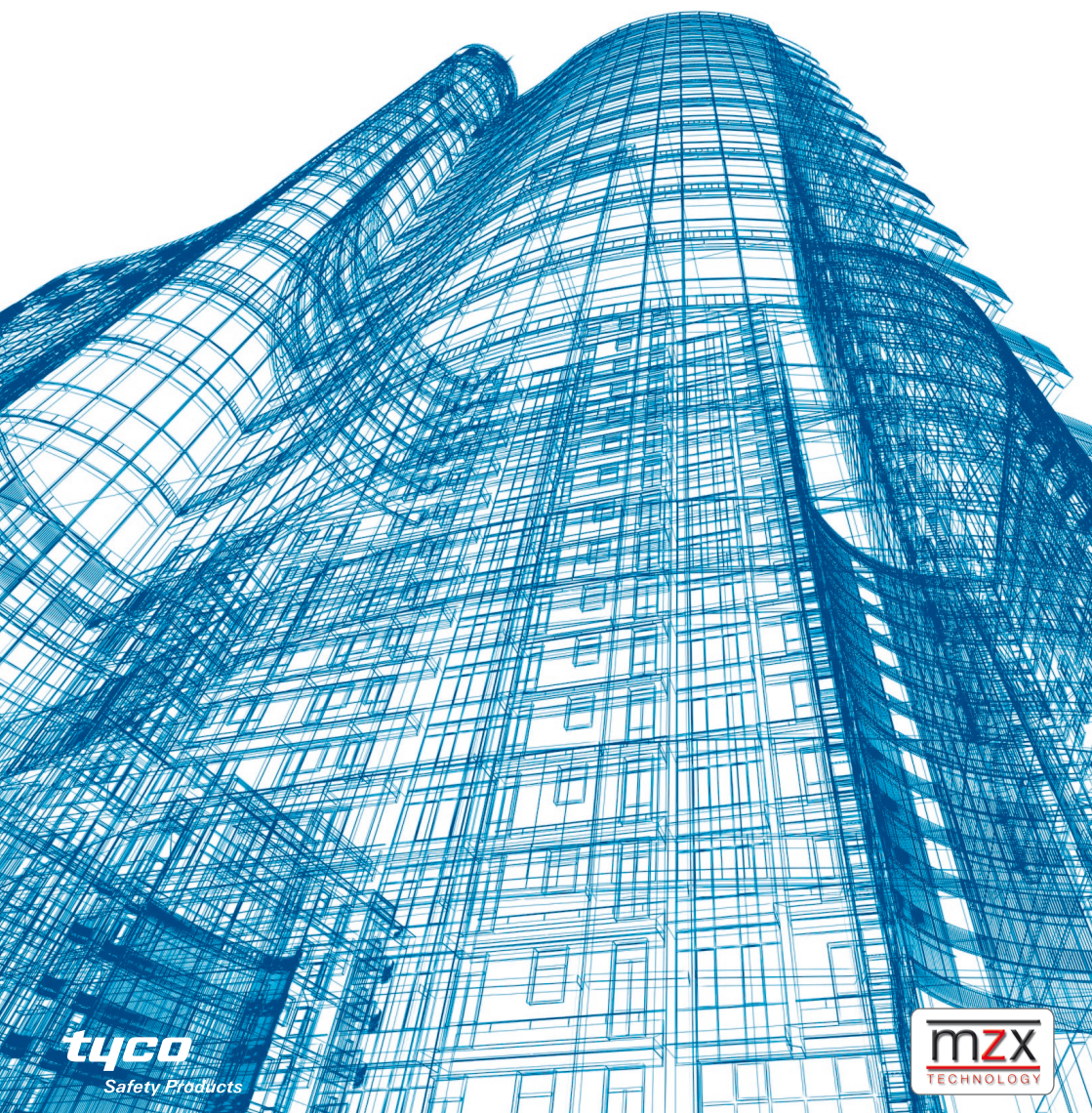

tyco
Safety Products

mzx
TECHNOLOGY

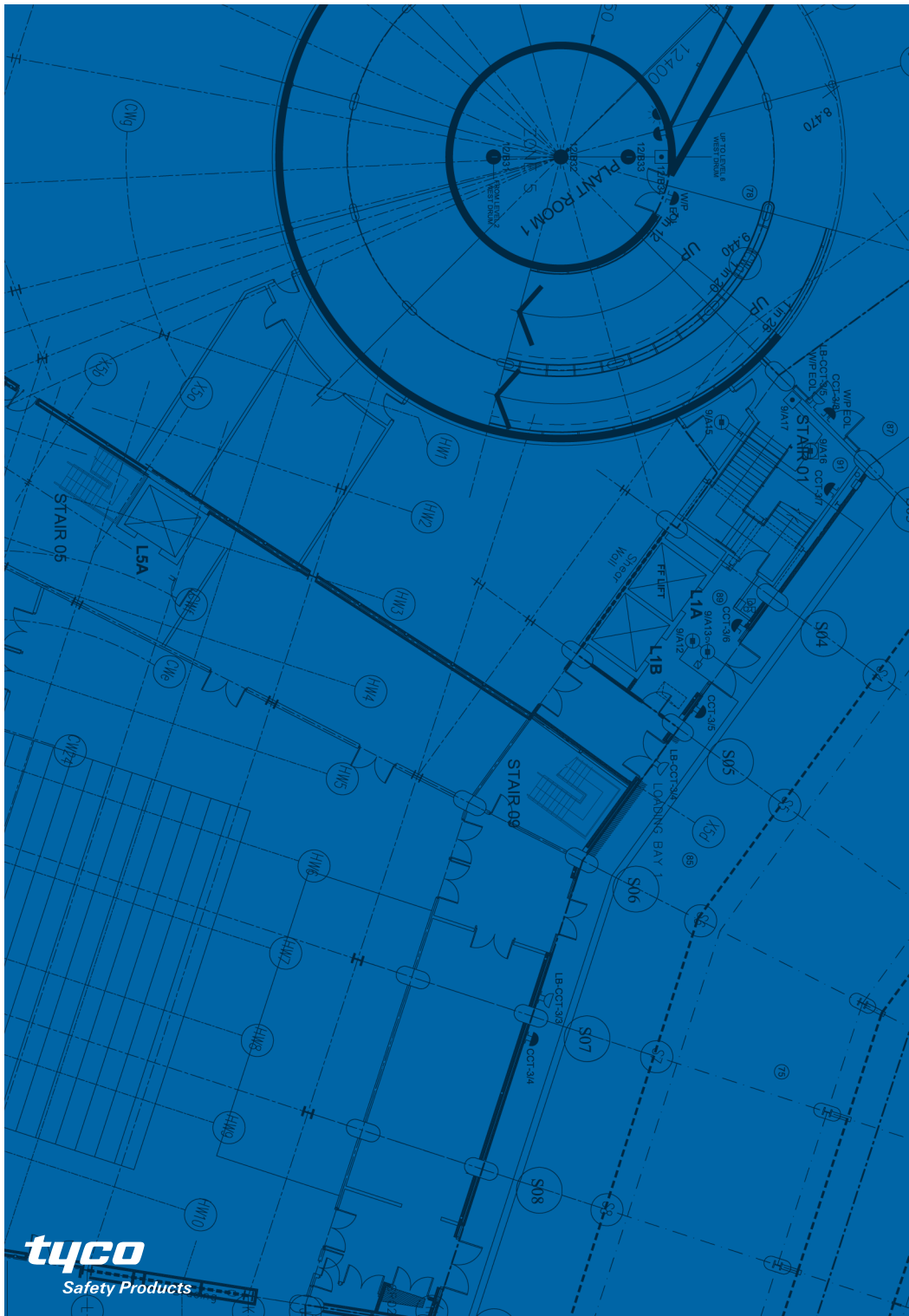

tyco

Safety Products

part one | guide to design of fire systems

contents

About this manual	Purpose	1
	Readership	3
	Electronic Format	4
	Acknowledgments	4
Part One: Guide to Design of Fire Systems		
1.	Introduction	7
1.1	Planning the System	9
1.1.1	The role of fire risk assessment and fire engineering	10
1.1.2	Variations from BS 5839-1	11
1.1.3	Type of system	12
1.1.4	Servicing arrangements	12
1.1.5	Planning flowchart	14
2.	Selecting the category of protection and coverage	16
2.1	Category M – manual	17
2.2	Category L5 – life	17
2.3	Category L4 – life	18
2.4	Category L3 – life	18
2.5	Category L2 – life	19
2.6	Category L1 – life	20
2.7	Category P2 – property	20
2.8	Category P1 – property	21
3.	How to configure detector zones and alarm zones within premises	22
3.1	The meaning of a detection zone and alarm zone	22
3.2	The purpose of detection zones	22

part one | guide to design of fire systems

contents

3.3	Detection zone configuration guidelines	23
3.4	Detection zone safeguards	24
4	Which type of fire detection system?	28
4.1	Conventional systems	28
4.1.1	Detection zones	28
4.1.2	Detectors and call points	29
4.2	Addressable systems	29
4.2.1	Operation of addressable systems	30
4.2.2	Detectors and call points	30
4.2.3	Output devices	31
4.3	Analogue addressable systems	33
4.3.1	Operation of analogue addressable detectors	33
4.3.1.1	Detector pre-alarm warning	35
4.3.1.2	Detector alarm threshold compensation	36
4.3.1.3	Detector condition monitoring	37
4.3.1.4	Detector sensitivity setting	38
5.	Detector suitability	40
5.1	General fire system engineering principles	40
5.2	Detector selection for a particular area	42
5.2.1	Smoke detectors	42
5.2.2	Heat detectors	45
5.2.3	Heat-enhanced Carbon monoxide fire detectors	47
5.2.4	Flame detectors	50
5.2.5	Optical beam detectors	51
5.2.6	Aspirating detectors	55
5.2.7	Duct probe unit	56
6.	Detector coverage	58
6.1	Spacing under flat ceilings	58
6.2	Spacing under pitched ceilings	60
6.3	Spacing in corridors	61
6.4	Stairways	61
6.5	Lift shafts and other flue-like structures	62
6.6	Obstructions	62

part one | guide to design of fire systems

contents

6.7	Honeycomb ceilings	64
6.8	Closely spaced structural beams and floor joists	65
6.9	Ceiling heights	67
6.10	Walls and partitions	68
6.11	Voids	70
6.12	Perforated ceilings	70
6.13	Ventilation	71
6.14	Lantern-lights	72
7.	Manual “break glass” call points	73
7.1	General information	73
7.2	Siting of manual call points	73
8.	Limitation of false alarms	76
8.1	Role of the designer	76
8.2	Categories of false alarm	79
8.3	Requirements for service technicians	79
8.4	False alarm ‘rates’	80
8.5	Causes of false alarms	83
8.6	Practical measures to limit false alarms	84
8.6.1	Siting and selection of manual call points	85
8.6.2	Selection and siting of automatic fire detectors	86
8.6.3	Selection of system type	90
8.6.4	Protection against electromagnetic interference	90
8.6.5	Performance monitoring of newly commissioned systems	91
8.6.6	Filtering measures	92
8.6.7	System management	96
8.6.8	Servicing and maintenance	97
9.	Means of giving warning to occupants	98
9.1	Sound pressure level	98
9.2	Discrimination and frequency	101
9.3	Sound continuity	101
9.4	Audible alarms in noisy areas	101
9.5	Alarm zones	102
9.6	External fire alarm devices	103

part one | guide to design of fire systems

contents

9.7	Voice alarm systems and voice sounders	103
9.8	Fire alarm warnings for deaf people	104
10.	Control and indicating equipment	105
10.1	Siting of control and indicating equipment	105
10.2	Location of origin of the fire	106
10.3	Security of control equipment	107
10.4	Networked control panels	107
11.	Power supplies	108
11.1	Mains supply	108
11.2	Standby supply	109
11.2.1	Life protection (category M and L systems)	109
11.2.2	Property protection (category P systems)	110
11.2.3	Calculation of standby battery capacity	110
12.	Cabling considerations	113
12.1	Recommended cable types	113
12.2	Cable suitability	114
12.3	Conductor sizes	117
12.4	Segregation	117
12.5	Cable colour coding	118
12.6	Joints in cables	118
12.7	Cable support	119
12.8	Mechanical protection of cables	120
13.	Communication with the fire service	121
13.1	Automatic transmission of alarm signals	122
13.1.1	Category L systems	122
13.1.2	Category P systems	123
13.2	Methods of automatic transmission	123
13.3	Standards for Alarm Receiving Centres (ARCs)	123

part one | guide to design of fire systems

contents

14.	System installation	124
14.1	Siting of equipment	125
14.2	Installation work	125
14.3	Inspection and testing	126
14.4	Commissioning and handover	127
15.	Documentation	131
16.	Maintenance	133
16.1	Routine testing	133
16.2	Servicing	134
17.	Responsibilities of user	136

part two | specification for an analogue addressable fire system

contents

Part Two: Specification for an Analogue Addressable Fire System		
1.	General Requirements	139
2.	Standards and Specifications	141
3.	Control and Indicating Equipment	144
3.1	General Requirements	144
3.2	System Configuration	145
3.3	Mechanical Design	147
3.4	Basic System Functions	147
3.5	Alarm Monitoring Functions	149
3.6	Alarm Output Functions	150
3.7	Supervision and Fault Reporting	152
3.8	System Management Facilities	153
3.9	Technical Specification	154
4.	Automatic Fire Detectors	155
4.1	General Requirements	155
4.2	Triple Sensing Detection	157
4.3	Ionisation Smoke Detectors	158
4.4	Optical Smoke Detectors	159
4.5	High Performance Optical Smoke Detectors	160
4.6	Infra Red Flame Detectors	161
4.7	Infra Red Array Flame Detection	162
4.8	Heat Detectors	164
4.9	Linear Heat Detectors	165
4.10	Beam Smoke Detectors	166
4.11	Aspirating Smoke Detectors	167
4.12	Carbon Monoxide (CO) Fire Detector	167
4.13	Remote Indicator Module	168

part two | specification for an analogue addressable fire system
contents

5.	Associated Ancillary Equipment	170
5.1	General Requirements	170
5.2	Addressable Manual Callpoints	170
5.3	Conventional Detector Interface Module (Including 4-20mA monitoring)	171
5.4	Addressable Relay Output Module	172
5.5	Addressable Contact Monitoring Module	172
5.6	Addressable Sounder Driver Module	173
5.7	Loop Powered Addressable Sounder Driver Module	173
5.8	Sounder Booster Module	173
5.9	Addressable Power Supply Module	174
5.10	Line Isolator Module	174
5.11	Door Control Module	174
5.12	Multiple Input/ Output Module	175
5.13	Single Input/ Output Module	176
5.14	Loop Powered Beam Detector Module	176
5.15	Addressable Loop Powered Sounder/ Beacon	176
5.16	Addressable Loop Powered Sounder/ Beacon Base	177
6.	Cables	179
6.1	Type	179
6.2	Containment	179
7.	Networking and Graphics	181
7.1	Sub Panels	181
7.2	Graphical Screen	181
8.	Documentation	185
8.1	Tender Documentation	185
8.2	Contract Documentation	185

part two | specification for an analogue addressable fire system
contents

9.	Installation	187
9.1	General	187
9.2	Materials	187
9.3	Installation of Detectors	188
9.4	Installation of Control Devices	189
9.5	Installation of Fire Controller Equipment	189
10.	Commissioning	191
10.1	General	191
10.2	Testing and Start-up	191
10.3	Commissioning	192
10.4	Handover	193
11.	Training	194
11.1	General	194
11.2	System Supervisor Training	194
11.3	Other Staff Training	194
12.	Maintenance	195
12.1	General	195
12.2	System Spares	195
12.3	System Test Equipment	196
	Appendix A	197
	Short Form Specification Key Points	197
	Control & Indicating Equipment	197
	Automatic Detectors	197
	Networking & Graphics	198
	Training	198

part one | guide to design of fire systems

about this manual

Purpose

The Code of Practice for fire detection and alarm systems for buildings (BS 5839- 1: 2002) is a detailed and comprehensive document which requires careful reading to fully understand its' requirements and latest approach to ensuring the safety of buildings and their occupants from the ever present threat of fire.

The purpose of this manual is to provide a step-by-step approach to the necessary guidelines described in BS 5839-1:2002, so that users can achieve maximum benefit from the recommendations. This should assist in the task of choosing the best options, help in preparing the specification of the fire protection system and assist architects, designers and electrical engineers in providing the most cost effective system solution that meets the needs of the user.

This manual is a consultants guide to the contents and usage of the British Standard Code for the design, installation and maintenance of fire detection and alarm systems for buildings (BS 5839-1: 2002). Throughout the manual, where it was necessary to reference this long title, we will simply refer to it as 'the Code'.

The Code is divided into seven sections. The first section is intended to be of general interest to all users, the second is intended to be of interest to the system designer, architect or electrical engineer. The third section attempts to address one of the major problems plaguing fire detection systems in Britain today, that of false and unwanted alarms. This section offers advice and best practices for the successful management of false alarms. The fourth section is for the installer with a link to section five which covers commissioning and handover of the system. Section

part one | guide to design of fire systems

about this manual

six recognises the importance of good planned maintenance and the seventh section is for the user. Each section contains commentary followed by recommendations. It is the recommendations that are used to audit a system.

In practice, more than one organisation or company is usually involved in the design of the system and its installation. The Code recognises these different responsibilities and takes a modular approach to the process of contracting when installing a fire alarm system. Furthermore, the Code recognises that, in most cases, the user is unlikely to buy a copy of the Code in order to learn about his responsibilities. In fact, the Code recommends that the installer should instruct the user on his responsibilities.

It is often a requirement that individual organisations or individual persons need to be familiar with all aspects of the Code. In this manual, therefore, we

follow through the design phase, the installation phase and use of the system phase without strictly following the Code as sectionalised.

This manual is a guideline to the Code only and as such it is important to read this manual in conjunction with the Code so that all aspects can be fully understood.

This manual is not a replacement for the Code.

The manual consists of two parts.

Part 1: Guide to Design of Fire Systems

This part contains information taken from the planning and design guidelines described in BS 5839-1:2002.

part one | guide to design of fire systems

about this manual

Part 2: Specification for an Analogue Addressable Fire System

This part contains a sample specification for an analogue addressable fire system. The information in the specification may be edited and used in specifications for fire system designs as appropriate. The text of the specification is provided on the CD-ROM included with this manual (see the CD-ROM section below for further details). By using the sample specification included on the CD-ROM, you can save yourself a considerable amount of time and effort because much of what is contained in the sample specification is applicable to almost all fire protection system designs. Simply load the specification file into your favourite word processing package and edit it to reflect the specification of your system design. Although the sample specification describes the most common elements of an analogue addressable

fire system design, you will obviously have to delete some existing clauses and add new clauses as appropriate in order to produce a definitive specification of your design.

Readership

This manual has been prepared for use by architects, designers and electrical engineers responsible for the design, specification and installation of fire protection and alarm systems intended for use in medium to large size buildings, for example, schools, hotels, hospitals, office complexes, shopping precincts, supermarket stores, airports, warehouses, etc.

The information provided herein is intended specifically for the use of appropriately qualified and experienced persons as stipulated in the Foreword to BS 5839-1:2002.

part one | guide to design of fire systems

contents

Electronic Format

This document is available for download in PDF format. Part 2 of this manual is a sample specification for analogue addressable fire detection systems, which is also downloadable in Word format from www.tycoemea.com

Acknowledgements

We gratefully acknowledges the use of certain extracts taken from the Code and thanks the British Standards Institution for allowing the use of some of its material.

part one | guide to
design of fire systems

part one | guide to design of fire systems

introduction

1. Introduction

Fire detection and alarm systems are designed to provide warning to the outbreak of fire, so allowing evacuation and appropriate fire fighting action to be taken before the situation gets out of control. Systems may be designed primarily to protect property or life, or to protect against interruption to a client's business from fire; some systems may be designed to achieve any combination of these objectives. It is essential that the designer understands the objective(s) of the system. This places a great responsibility on the designer because each building will present a different set of problems in relation to satisfying the objective. Each fire detection and alarm system therefore must be specifically designed to meet the requirements of the client for each building.

Once the objective(s) has been defined, in designing a system, particular consideration must be given to the type of building, its construction and the purpose for which it is being used, so that in the event of a fire, the fire detection system, combined with appropriate fire prevention procedures, will keep fire risk to a minimum.

The information provided herein is intended to help and enable appropriately qua-

lified designers to plan and design fire detection and alarm systems suitable for use in any type of building or installation.

As mentioned above, the designer of a fire detection and alarm system bears a great responsibility because the safety of personnel, property and the continuing operation of the business rests with him. Occasionally, particular problems may occur which are not covered in this manual. In such cases it is most important that you seek specialist advice at an early stage.

When designing a fire detection and alarm system, in addition to deciding the type of system, detectors, call points and sounders to be used etc., there are also other aspects which need to be considered. These include measures to limit false and unwanted alarms, method of installation, materials required during installation, user training, routine maintenance procedures, and service agreement. For any system to function reliably and provide problem free service throughout the life of the system, all of these aspects must be considered in the overall system design and plan.

What is the BAFE Modular Scheme?

The British Approvals for Fire Equipment (BAFE) modular scheme, SP203, was

part one | guide to design of fire systems

introduction

launched in 2002 and has been prepared for the third party certification of companies involved in the:

- Design
- Installation
- Commissioning and handover
- Maintenance of fire detection and alarm systems and/or fixed fire suppression systems.

The scheme has four modules in recognition of the fact that a different company may undertake each module. Thus, for example, a consulting engineer can be certificated under the scheme for design of fire detection and alarm systems, whereas fire alarm contractors will normally be certificated for all four modules. An electrical contractor, on the other hand, could be certificated purely for the installation module. The scheme is, therefore, designed to reflect the way in which fire alarm contracts actually operate, and it parallels BS 5839-1: 2002, which is divided into separate sections containing recommendations for design, installation, commissioning/ handover and maintenance.

A BAFE certificate of compliance is issued to the completed system, provided firms certificated under the scheme have been responsible for, and issued certificates for,

design, installation and commissioning. Before the BAFE certificate of compliance can be issued, however, an additional process, known as 'verification', must be carried out. This essentially ensures that the design drawn up at the beginning of the process remains valid at the end of the process.

What is LPS 1014?

LPS 1014 is a standard against which the Loss Prevention Certification Board (LPCB) assesses the ability of companies to design, install, commission and service fire detection and alarm systems.

This scheme has also been adopted by BAFE.

By specifying a company which is certificated to LPS 1014, you can be confident that your fire detection and alarm system will be installed competently to the codes of practice that you specify (e.g. BS 5839-1: 2002) and that the company can provide the necessary maintenance service required to maintain a valid LPS 1014 Certificate of Conformity.

For a company to be LPS 1014 Certificated it must fulfil the following requirements:

part one | guide to design of fire systems

introduction

- Have two years continuous experience in design, installation, commissioning and servicing of systems.
- Have randomly selected installations inspected by the LPCB every six months against the specified contract requirements. Certificates must reliably identify any variations from the Installation Rules applied.
- Have the resources to support systems in case of a break down with 8-hour emergency call out service.
- Be competently capable of performing the planned servicing of installations.
- Have suitably trained and experienced staff.
- Operate a BS EN ISO 9000 quality system.

When an LPS 1014 approved company completes each installation contract, the client is issued with a Certificate of Conformity. Copies of these certificates are also forwarded to the LPCB. The LPCB use their copies of the certificates to choose randomly which installations to inspect.

An installation designed, installed, commissioned and maintained by a firm certificated under LPS 1014 will be likely to meet the statutory requirements of the fire brigade and satisfy your insurance com-

pany, provided their requirements have been taken into account in the design.

1.1 Planning the System

This task is probably the most important of all because mistakes made here may have a fundamental effect on the category and operation of fire detection and alarm system. The specification and associated documentation which form the invitation to tender will indicate any weaknesses, errors or omissions in the design. The specification of the system therefore should be prepared with great care, thus ensuring that all requirements of the system are covered.

Clause 6 of BS 5839-1: 2002 defines the responsibilities of the designer of the system, particularly in terms of exchange of information and consultation with other parties.

The key parties with whom the designer needs to consult are the user or purchaser of the system and any relevant consultants, including architects, M&E consultants and fire engineering consultants.

Before design begins, the designer should ensure that he understands the objectives of the system. Is it merely to satisfy legisla-

part one | guide to design of fire systems

introduction

tive requirements for the protection of life? Instead, or in addition, is it to protect property, perhaps in order to satisfy insurers' requirements? Is it intended to minimize disruption to the business in the event of fire? It is the responsibility of the user or purchaser of the system (or a consultant acting on their behalf) to consult with the relevant enforcing authorities (e.g. building control and the fire authority) and, where relevant, the insurers to determine their requirements. These requirements should then be passed on to the designer. Where the designer is in any doubt, he should endeavour to clarify the requirements by discussion with the user or purchaser, and he should make clear to the client the nature and objectives of the protection that he proposes to design.

The design of the system should be 'driven' by the fire safety strategy for the building, including the required evacuation procedures. For example, to support the procedures, a two-stage alarm might be necessary. It is too late to develop fire procedures once the system has been designed. The designer needs to understand the client's intended fire procedures to ensure that these can be supported by the system. On the other hand, at the time of initial design, sufficient information is not always availa-

ble. In such cases, the consultant may need to leave some flexibility for amendment of the design to suit the final procedures and the particular system that is supplied.

1.1.1 The Role of Fire Risk Assessment and Fire Engineering

The Regulatory Reform (Fire Safety) order 2005, introduced in October 2006, simplified the law on fire safety by replacing over 70 separate pieces of fire safety legislation. The order now placed those responsible for fire safety in business ('responsible persons') to carry out a fire risk assessment, and the findings must be documented if the employer employs five or more employees. This requirement applies even if the premises have been accepted by enforcing authorities under other fire safety legislation, such as the Fire Precautions Act. The 'Responsible Person' needs to identify the fire precautions that should be taken by means of a fire risk assessment. The designer of a fire alarm system for an existing building needs to be aware of any relevant findings of the fire risk assessment.

Most buildings will need a manual fire alarm system to protect occupants. Where people sleep in the building, comprehensi-

part one | guide to design of fire systems

introduction

ve coverage by fire detection will also be necessary. The fire risk assessment might also identify the need for fire detection in specified areas of a building in which no one sleeps. Sometimes, the fire detection is necessary to compensate for shortcomings in other fire precautions, in which case the fire risk assessment should identify the level of coverage required.

The fire precautions, such as means of escape, in many complex modern buildings do not necessarily follow the guidance in traditional 'prescriptive' codes of practice. Instead, a 'fire engineering solution' is adopted, whereby a package of integrated fire protection measures achieve a standard of fire safety that is, at least, equivalent to the safety offered by the prescriptive code. Often, automatic fire detection is one of the measures included in the package. The designer of the fire alarm system should take great care, in this case, to ensure that the system meets the needs of the fire engineering solution. This might necessitate consultation with the fire engineer responsible for the fire engineering solution.

1.1.2 Variations from BS 5839-1

BS 5839-1 is a code of practice, rather than a rigid standard. It contains recommendations that will be suitable in most circum-

stances, rather than inflexible requirements. This means that the consultant may adopt 'variations' from the recommendations of the code to suit the particular needs of the building.

This does not mean that the recommendations should be ignored. They should always be considered and, normally, followed. However, the designer might adopt a variation on the basis of a fire risk assessment or his engineering judgement, practical considerations arising from installation difficulties, to achieve a cost effective design, etc. A variation could be as simple as a small departure from some dimension specified in the code (e.g. maximum distance of travel to the nearest manual call point) or as significant as the omission of fire detectors from an area that is judged to be of such low hazard as to make fire detection unnecessary.

Care should be taken to ensure that the recommendations of the code regarding variations are followed exactly. The specific recommendations in question are that:

- The variations should be clearly identified, so that they are obvious to all interested parties, such as the user, purchaser, enforcing authority or insurer.

- The variations should be agreed by all the interested parties.

All variations should be listed in the design certificate that is issued by the consultant.

1.1.3 Type of System

Early in the planning of the system, the consultant needs to consider what type of system is appropriate. For example, consideration should be given to whether the system should be conventional or analogue addressable. The two types of system are compared and contrasted in Section 4. As a general rule, conventional systems are appropriate only in buildings of limited size and complexity, where a simple indication of the zone in which there is a fire will be sufficient. In other buildings, an indication of the exact location of the detector(s) that has responded to a fire, provided by an addressable system, will be of value.

Analogue addressable systems are recognised as having a lower potential for false and unwanted alarms than conventional systems. The code recommends that systems with a high number of smoke detectors (e.g. more than 100 detectors) should be of the analogue addressable type.

Early consideration of the type of detectors to be used will also be needed. Heat detectors will be the most immune to false and unwanted alarms in most circumstances, but will not generally provide as early a warning of fire as smoke detectors or multisensor fire detectors. In some circumstances, multisensor fire detectors can provide early warning of fire with less potential for false and unwanted alarms than smoke detectors. Flame detectors may be appropriate for special risks, such as areas in which there are flammable liquids.

1.1.4 Servicing Arrangements

Servicing arrangements are important because they represent a hidden cost to the user. Some systems may require regular attendance by a service engineer in order to maintain the system at a high efficiency level. Not only does the engineer have to be paid for, but his presence may also cause disruption to the day-to-day operation of the business. The latter element may actually be much more important to the end user than the service cost.

Section 6 of the code specifies recommendations for maintenance. This includes weekly tests and periodic inspection and servicing. Clause 45.3 states that, if some

part one | guide to design of fire systems

introduction

of the functions are tested automatically then the manufacturer can specify that some periodic testing can be omitted. This can pay off in servicing requirements since the end user can see the financial advantages of such a system. It should be noted that, if servicing requirements are included, it means that the quotation should also include the costs of the recommended system maintenance.

1.1.5 Planning Flowchart

To assist with designing and specifying a typical fire alarm system the planning flowchart shown in Figure 1 overleaf has been produced to provide a logical guide. This flowchart maps the main activities that should be considered when planning and designing a fire detection and alarm system. The side notes added to certain activity boxes are included for the purpose of directing the reader to relevant sections of this manual, where further detailed information can be found.

part one | guide to design of fire systems
introduction

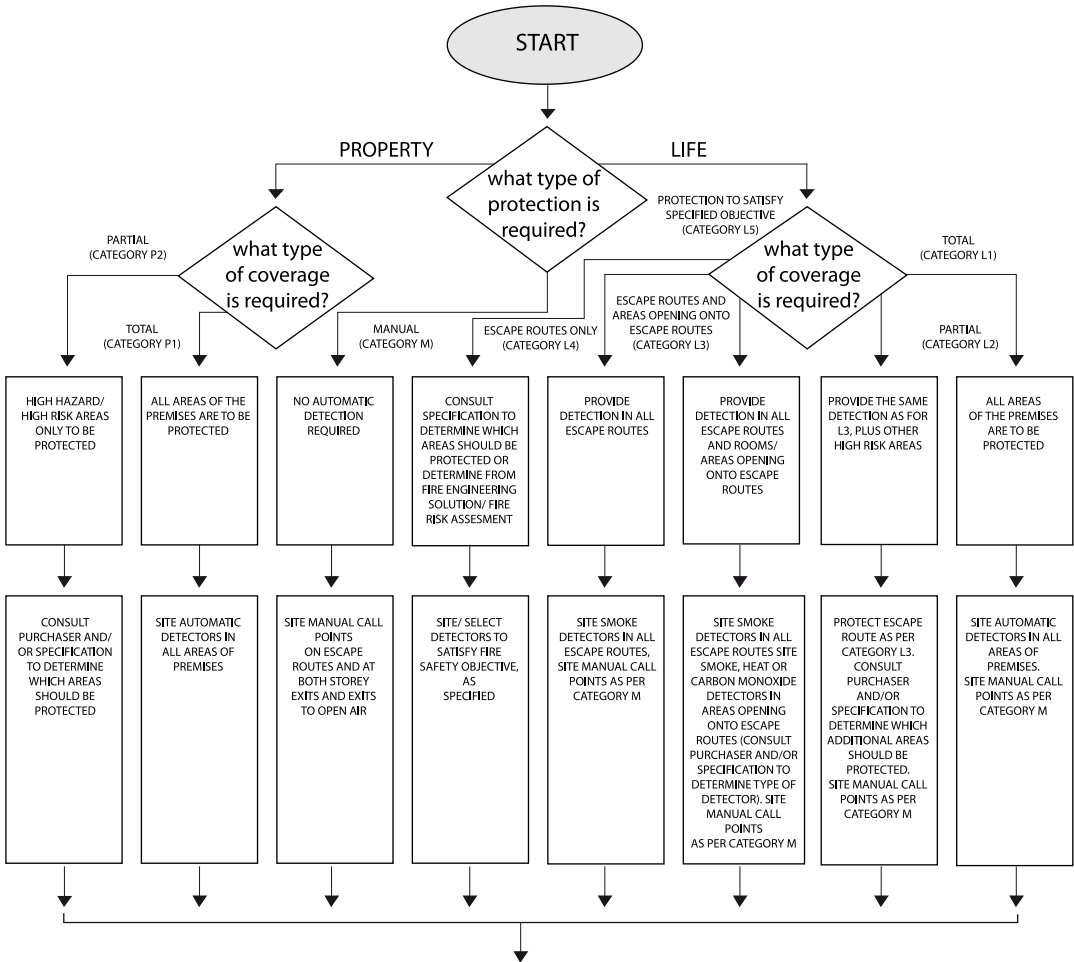

fig 1. Fire Planning and Design Flowchart (part1)

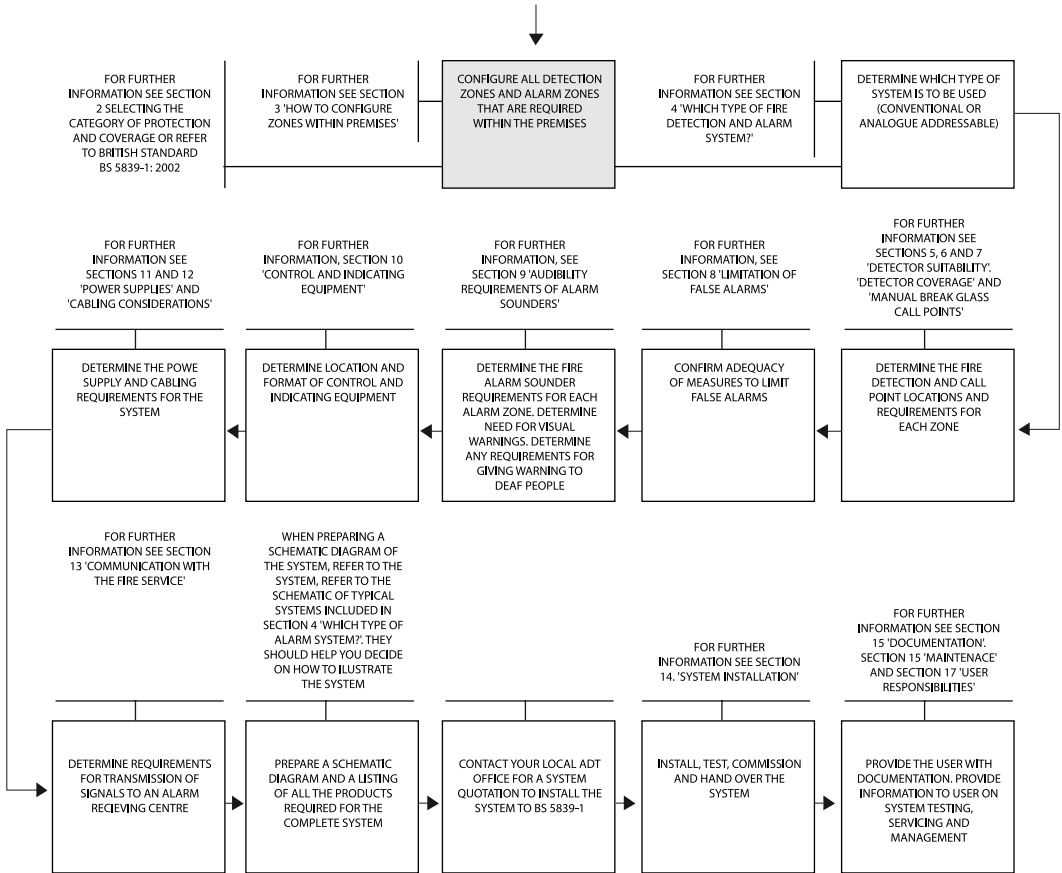

fig 1. Fire Planning and Design Flowchart (part2)

part one | guide to design of fire systems

selecting the category of protection and coverage

2. Selecting the Category of Protection and Coverage

After initially consulting with all interested parties, the first decision to be made when designing a fire detection and alarm system is a simple choice of establishing the purpose of the system, that is whether it is for protecting the building, its contents and business continuity (Property Protection) or enhancing the safety of the occupants (Life Protection). British Standard BS 5839-1: 2002 categorises systems according to their purpose and the extent of protection to be afforded.

If it is determined that there should be no automatic detection, a simple system comprising sounders and break glass call points alone might suffice. This type of system is described as a Category M system.

- **Manual (Category M)**

Category M

A manual system, incorporating no automatic fire detectors.

Clause 5 of the code divides systems that incorporate automatic fire detection into two main Categories, according to whether the objective is life safety (Category L) or property protection (Category P). The two Categories are then further sub-

divided, according to the extent of coverage by automatic fire detection.

- **Life Protection (Category L)**

This classification provides for the protection of life, that is the safety of the occupants. It caters for the detection of a fire, initiates an alarm of fire, and provides sufficient time for the occupants to escape from the building.

Category L5

The protected area and/or the location of detectors is designed to satisfy a specific fire safety objective. This may be defined in a fire engineering solution or from a fire risk assessment.

Category L4

Covers those parts of the escape routes comprising circulation areas and circulation spaces, such as corridors and airways.

Category L3

Covers escape routes and rooms opening onto escape routes (detectors may be situated adjacent to the door onto the escape route).

part one | guide to design of fire systems

selecting the category of protection and coverage

Category L2

Covers the areas protected by Category 3 system plus other areas where it is considered that there is a high fire hazard and/or fire risk.

Category L1

Total coverage throughout the building.

• Property Protection (Category P)

This classification provides for the protection of property and its contents. It caters for the automatic detection of a fire, initiates an alarm of fire, and results in summoning of the fire brigade (which may be by a means of automatic transmission of fire signals to an Alarm Receiving Centre).

Category P2

Covers areas of high fire hazard or high risk to property or business continuity from fire.

Category P1

Total coverage throughout the building.

2.1 Category M – Manual

This is the simplest form of fire alarm system. It provides basic protection by break glass call points and sounders only. As this type of system has no automatic detection

devices, in the event of fire, it has to be manually initiated by activating a call point.

2.2 Category L5 - Life

Often the design of a Category L5 system is based on a fire risk assessment or arises from a fire engineering solution. The system may be provided to compensate for some departure from the normal recommendations of prescriptive fire protection codes, such as those dealing with means of escape. A Category L5 system may also be provided as part of the operating system for a fire protection system (e.g. a smoke control system).

The Category L5 system could be as simple as one that incorporates a single automatic fire detector in one room, but a Category L5 system could also comprise comprehensive fire detection throughout large areas of a building in which, for example, structural fire resistance is less than that normally specified in the circumstances.

The protection afforded by a Category L system might, or might not, incorporate that provided by a Category L2, L3 or L4 system.

part one | guide to design of fire systems

selecting the category of protection and coverage

2.3 Category L4 - Life

In a Category L4 system, automatic fire detection is only provided within escape routes comprising circulation areas and circulation spaces, such as corridors and stairways. A Category L4 system will not necessarily provide significant time for all occupants to escape before smoke occurs in significant quantities within the escape routes. This level of protection will not, therefore, normally satisfy the requirements of legislation in buildings in which people sleep.

The objective of a Category L4 system is to enhance the safety of occupants by providing warning of smoke within escape routes. This may be satisfactory in a building in which legislation would not, in any case, require automatic fire detection. Although the need for a Category L4 system might be identified in a fire risk assessment, care should be taken to ensure that the absence of detectors within rooms opening onto escape routes (as would be found in a Category L3 system) is satisfactory to ensure the safety of occupants. There is, of course, nothing to prevent the installation of detectors in certain additional areas over and above the minimum necessary for compliance with the recommendations for a Category L4 system.

Detectors installed within the escape routes can be optical, CO or multisensor detectors.

2.4 Category L3 - Life

The purpose of a Category L3 system is to provide warning to occupants beyond the room in which fire starts, so that they can escape before escape routes, such as corridors and staircases, are smoke-logged. However, research has shown that fire gases passing through the cracks around doors can produce smoke sufficiently dense and cool for a corridor to become smoke-logged before adequate warning can be given by detectors in the corridor itself.

For this reason, in a Category L3 system, optical smoke detectors, or a mixture of optical smoke detectors, CO and or multisensor fire detectors, should be sited within the escape routes, while smoke, heat or carbon monoxide detectors should be installed in all rooms that open onto the escape routes. (Rooms opening onto corridors of less than 4m in length need not, however, be protected, providing fire resisting construction, including doors, separates these short corridors from any other section of the escape route.)

part one | guide to design of fire systems

selecting the category of protection and coverage

An open plan area of accommodation, in which occupants will quickly become aware of a fire, need not be protected in a Category L3 (or L4) system unless the area forms part of the escape route from other areas (e.g. an enclosed office). However, in a Category L3 system, detection should be installed on the accommodation side of any door within the open plan area that opens into the escape routes (subject to the exception for the short lengths of corridor described above).

2.5 Category L2 - Life

The objective of the Category L2 system is identical to that of a Category L3 system, with the additional objective of giving early warning of a fire that occurs in specified areas of high fire hazard (i.e. where the outbreak of fire is likely) and/or areas of high fire risk (i.e. where the likelihood of fire in combination with the possible consequences of fire warrants protection).

It is for the designer to specify which rooms or areas of the building warrant protection, over and above the protection provided in a Category L3 system. It should not be left to the fire alarm contractor to guess the intention of the designer in this respect.

Upgrading Category L3 protection to Category L2 protection might not only involve provision of detectors in additional rooms or areas. It might involve a change in detector type and/or siting. For example, many building control and fire authorities accept heat detection within bedrooms of hotels, as they consider the purpose of these detectors is only to provide a warning of fire to occupants of other bedrooms, rather than the occupant of the room in which fire starts. Since this is effectively Category L3 protection, these detectors may also be wall-mounted on the walls of the bedrooms. However, in the case of a dormitory, this would be insufficient, and smoke detection would normally be required throughout the dormitory. Also, if any bedrooms are intended for use by disabled people, earlier warning of fire within the bedroom is necessary to provide additional time for escape. Again, in these bedrooms, the authorities would require smoke detectors (or, possibly, carbon monoxide fire detectors), and the detectors would be conventionally mounted on the ceiling. These smoke or carbon monoxide multisensor detectors, intended to protect the occupants of the room in which fire starts, are effectively part of a Category L2 system.

part one | guide to design of fire systems

selecting the category of protection and coverage

2.6 Category L1 - Life

A Category L1 system provides the highest standard of protection of life. Fire detectors are installed in all rooms and areas of the building, except that the following rooms or areas need not be protected if they are of low fire risk:

- Toilets, shower rooms and bathrooms;
- Stairway, lobbies and toilet lobbies;
- Small cupboards (typically, less than 1m²);
- Small risers (typically, less than 1m²), if there is a fire resisting floor and ceiling within the riser.
- Some shallow voids (less than 800mm in depth).

In a Category L1 system, the detectors within escape routes should be optical smoke detectors, or multisensor fire detectors.

2.7 Category P2 - Property

A Category P2 system involves automatic fire detection in only specified areas of the building. The areas in which detection should be provided are those that are judged to have a high probability of fire and those in which the consequences of fire would be serious. In

considering the consequences of fire, account should be taken of both direct damage to property and the effect of fire on business continuity. As in the case of a Category L2 system, the specification should indicate the areas in which automatic fire detection is to be provided. It should not be left for the fire alarm installer to guess the designer's intent in this respect. The designer should, therefore, determine the requirements of the purchaser, who in turn should consult with the property insurers.

Points to consider in determining the need for protection in any area include:

- How probable is the likelihood of detection by people in the building?
- What sources of ignition are present?
- How combustible are the contents?
- How valuable are the contents?
- What is the likelihood of fire spreading from unprotected areas to areas with valuable contents or areas on which business continuity depends?
- What are the costs of extending the protection to all areas?

Usually, some form of balance has to be struck between cost and level of protection. BS 5839-1 gives no detailed advice in this respect, and so great care needs to be

part one | guide to design of fire systems

selecting the category of protection and coverage

taken to ensure that the system will satisfy the objectives of the purchaser or user.

2.8 Category P1 - Property

A Category P1 is very similar to a Category L1 system, in that all areas of the building are protected, other than the exceptions described for Category L1. Thus, a Category P1 system provides the highest form of protection of property and protection against interruption to a business. It is, therefore, the most ideal system from the point of view of the property insurer.

part one | guide to design of fire systems

how to configure detector zones and alarm zones within premises

3. How to Configure Zones within Premises

3.1 The Meaning of a Detection Zone and Alarm Zone

BS 5839-1: 2002 defines a detection zone as 'a subdivision of the protected premises such that the occurrence of a fire within it will be indicated by a fire alarm system separately from an indication of fire in any other subdivision'. The code notes that a detection zone will usually consist of; an area protected by several manual call points and/or detectors, and is separately indicated to assist in location of the fire, evacuation of the building and fire-fighting. In earlier versions of BS 5839-1, a detection zone was described simply as a 'zone'.

The code defines an alarm zone as 'a geographical sub-division of the premises, in which the fire alarm warning can be given separately, and independently, of a fire alarm warning in any other alarm zone.' Thus, alarm zones do not occur in buildings in which there is single phase (simultaneous) evacuation of the entire building when the fire alarm system is operated. Alarm zones only occur in buildings in which there is a two (or more) stage alarm.

3.2 The Purpose of Detection Zones

The main reason for sub-dividing the premises into detection zones is to indicate the location of a fire as precisely as possible at the control and indicating equipment (CIE). This aids those responding to the fire alarm signal, particularly the fire service.

In conventional systems, each detection zone is connected to the CIE by a separate circuit. In addressable systems, however, one circuit may serve a large number of manual call points and detectors, grouped into several detection zones. In either case, each detection zone will have a separate number and visual indicator at the CIE. In the event of a fire condition, the visual indicator will illuminate, thus assisting people to identify the location of the fire by means of a zone plan, which should be mounted adjacent to the CIE.

Addressable systems are able to identify exactly which detector or call point is in the alarm condition, so pinpointing the exact location of the fire. Notwithstanding this major benefit of being able to locate precisely the origin of the fire, the building needs to be sub-divided into detection zones in accordance with clause 13 of the code. In general, the code states that the primary indication of the origin of the alarm

part one | guide to design of fire systems

how to configure detector zones and alarm zones within premises

should be an indication of the detection zone of origin.

A display giving information only relating to the whereabouts of a particular detector in alarm (for example, CIRCUIT 2 DETECTOR 7 WORKS OFFICE) is useful, but in isolation may not provide an obvious indication of the spread of fire as further detectors go into alarm. The display of individual detectors in alarm should, therefore, be secondary to the light emitting visual indication of detection zone.

To satisfy this recommendation, a separate and continuous visible indication for each detection zone in which a detector or call point has operated will need to be given on the control and indicating equipment, or on a separate indicator panel connected to it.

3.3 Detection Zone Configuration Guidelines

There are several recommendations regarding the size and configuration of a detection zone that are common to both conventional and addressable fire systems:

1. The maximum floor area of a detection zone should not exceed 2,000m². (However, in large, open plan areas, such as warehouses, if the detection zone only contains manual call points, this may be increased to 10,000m².)
2. The search distance, that is the distance that has to be travelled by a searcher within a detection zone in order to determine visually the position of the fire (not reach the fire), should not exceed 60m. (Search distance need not be applied to addressable systems if a suitable display of location would enable fire-fighters to go straight to the fire.)
3. If the total floor area of a building is less than 300m², then the building need only be one detection zone, regardless of the number of floors.
4. If the total floor area of a building is greater than 300m², then each floor should be a separate detection zone (or set of detection zones, if the floor area is large enough).
5. A single, vertical detection zone should be provided for fire detectors within an enclosed stairwell, lift shaft or similar enclosed flue-like structure. However, any manual call point on the landing of a stairwell

part one | guide to design of fire systems

how to configure detector zones and alarm zones within premises

should be incorporated within the detection zone that serves the adjacent accommodation on the same level as the landing.

3.4 Detection Zone Safeguards

It is possible for addressable detectors to share one circuit all round the building, thereby having several detection zones served by the same two-wire circuit. For conventional detectors, each individual detection zone is served by its own dedicated two-wire circuit.

To ensure that an addressable system does not have a lower level of integrity than a conventional system, the code makes various recommendations that limit the effects of faults.

1. A single fault occurring on an automatic fire detector circuit should not disable protection within an area of more than 2,000m², nor on more than one floor of the building plus a maximum of five devices on the floor immediately above and five devices on the floor immediately below that floor.

In conventional systems this will normally be achieved as a matter of course, since an open or short circuit

condition will only affect the individual detection zone circuit concerned (See Figure 2). The detection zone will be no more than 2,000m² in area and, other than in very small buildings, will serve no more than one floor.

In addressable systems where a number of zones share the same ring circuit or loop (See Figure 3), an open circuit is not too much of a problem (just so long as the fault is reported) since the loop can be driven in both directions. The case of a short circuit however is far more serious since this condition could prejudice every device (up to 250) on the circuit. Short circuit protection is therefore required in all loop circuits. This is achieved by placing line isolator devices at appropriate locations in the loop circuit, so that the area protected by detectors between any two line isolators is no greater than 2,000m² and these detectors are on the same floor level.

For example, with reference to the circuit shown in Figure 3, if a short circuit were to occur in detection zone 2, the two line isolators X and Y would operate and create two breaks in the circuit at points X and Y. The loop would

part one | guide to design of fire systems

how to configure detector zones and alarm zones within premises

then drive in both directions, that is, detection zone 1 in one direction and zones 5, 4 and 3 in the other direction. The line isolators would again automatically become passive after the short circuit has been repaired.

Each circuit serves no more than 2,000m² and no more than a single floor

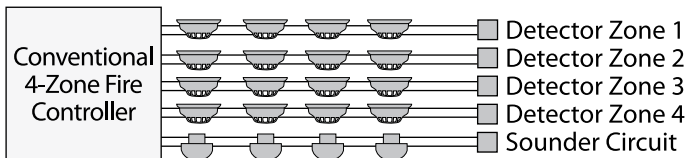



Key:  Detector or call point
 Sounder
 End of Line Device

fig 2. Conventional System Circuit

part one | guide to design of fire systems

how to configure detector zones and alarm zones within premises

Circuit 1 to 4; 250 points per circuit

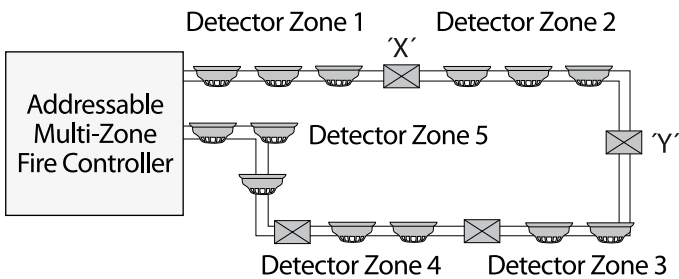



- Key:  Detector or call point
 Zone/ Line Isolator Module
 ('Y' may be omitted if Detector Zones 2 and 3 are small and both on the same floor)

fig 3. Addressable Loop System Circuit



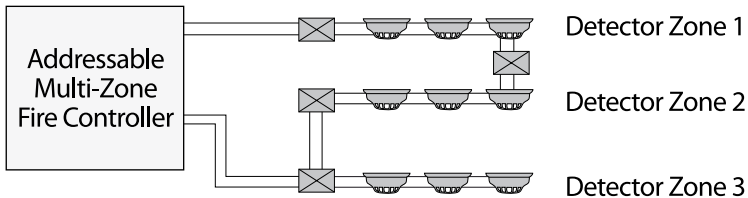

- Key:  Detector or call point
 Zone/ Line Isolator Module

fig 4. Addressable Loop System Circuit with Spurs

part one | guide to design of fire systems

how to configure detector zones and alarm zones within premises

In addressable systems where detectors are connected on a 'spur' off a loop, (see Figure 4), to comply with the recommendation of the code then the spur should not serve more than one floor or an area of greater than 2,000m².

When you have established the detection zone arrangement for the building, the next step in the design process is to decide which type of fire alarm system should be used, see section 4 (Which Type of Fire Detection and Alarm System?).

2. Two faults should not remove protection from an area greater than 10,000m². This recommendation imposes a maximum area of coverage for a single loop in an addressable loop system (see Figure 3). No loop in the system therefore should ever serve an area of coverage greater than 10,000m². If the area to be protected exceeds this maximum limit, then an additional loop(s) should be used.
3. Open circuit and short circuit faults should be reported at the control panel within 100 seconds of occurrence

This limitation will be satisfied if control equipment conforms to BS EN 54-2.

which type of fire detection system

4. Which Type of Fire Detection and Alarm System?

Three types of fire alarm detection systems are available and covered by the code. These types are broadly defined as:

- Conventional Systems
- Addressable Systems
- Analogue Addressable Systems

Irrespective of which type of system is selected, the guidelines set out in Sections 2 and 3 still apply.

In the following subsections, we compare and contrast the differences between the three types of systems.

4.1 Conventional Systems

A conventional or two-state detector is a detector which gives one of two states relating to either normal or fire alarm conditions.

Conventional systems provide a number of two wire circuits onto which conventional detectors and call points are connected. Similarly, separate two wire circuits are also provided for the purpose of connecting sounders (or alarm bells) to the system (see Figure 2 in Section 3).

The primary function of the control and indicating equipment (CIE) is to indicate the location of a fire as precisely as possible. To achieve this objective, detectors are grouped into detection zones, with each detector zone being connected to the CIE by a separate circuit, which also has a separate indicator on the control panel.

Each detector includes an integral LED (light emitting diode) indicator which illuminates when the device is in the fire alarm condition. If an indicator on the CIE indicates a fire in a detection zone, the detection zone must be physically searched until the detector with the illuminated LED is found. Detectors installed out of view normally have a remote LED indicator.

4.1.1 Detection Zones

If zoning were to be extended to the limit, each circuit would have only one detector connected, and the exact location of the fire could be established at the CIE without the need to physically search the zone. To do this with conventional detectors and a conventional control panel would be prohibitively expensive because of the number of detection zones required on the CIE and the large amount of installation work involved.

part one | guide to design of fire systems

which type of fire detection system

In conventional systems, all the detectors on a detection zone circuit continuously communicate with the CIE. When one detector goes into the fire alarm state, the voltage on the circuit drops and all other detectors on that detection zone become disabled. During this period no further signals from other detectors in the detection zone can be received at the CIE.

4.1.2 Detectors and Call Points

Point smoke detectors used in conventional systems must conform to the requirements of BS EN 54-7. Similarly, point heat detectors must conform to the requirements of BS EN 54-5. Flame detectors must conform to the requirements of BS EN 54-10.

Manual break glass call points must conform to the requirements of BS EN 54-11. The code recommends the use of 'Type A' manual call points, which require only one action to operate them (i.e. breaking the glass automatically sets off the fire alarm system). However, if manual call points are likely to be subject to casual malicious operation (e.g. in some schools, student residences, public entertainment premises, etc), a variation might be accepted by the building control and fire authorities, whereby on next time a hinged plastic cover is fitted to each call point. The cover

then has to be lifted before the glass can be broken.

The code states that the removal of a detector on a circuit should not prevent the operation of any break glass call point. In a conventional system, unless the system is designed in such a way that removal of every detector from a detection zone circuit does not disable other devices that remain connected, it will be necessary to either connect manual call points on a separate circuit from fire detectors or to install all call points as the first devices on the circuit, with any automatic fire detectors 'downstream' of these.

4.2 Addressable Systems

An addressable system is one using addressable detectors and/or call points, signals from which are individually identified at the control panel.

In a simple addressable system, the CIE can provide a number of two wire circuits onto which addressable detectors and call points may be connected. The two wire circuit should be connected to form a loop in order to provide circuit integrity. In addition to this, line isolators should be distributed around the loop to ensure compliance with the code.

which type of fire detection system

4.2.1 Operation of Addressable Systems

In an addressable system, multiplex communication techniques allow each detector to independently signal its status back to the control panel. Since each detector has its own identity (or address) the control panel, in addition to providing the normal detection zone, may also be configured to give a customer defined character message to each detector. This is especially useful to any observer who is not familiar with the layout of the site. The customised messages are usually displayed on a LCD display alongside the visual detection zone indicators.

In operation, the control panel sends out the first address and then waits a pre-set time for a reply. Each detector compares the address sent out by the control panel with its own pre-set address and the one that matches the address sends back its status. If a particular detector address is not found within the pre-set time because the device has been either disconnected or removed, the control panel indicates a fault. Similarly, if the detector address is found but the device fails to operate correctly (that is, reply) within the pre-set time then the control panel also indicates a fault.

The control panel then sends out the next address, and so on until all devices have been addressed, and then it repeats the whole cycle again.

Clearly it is possible for many detectors on the same circuit to be in alarm at the same time and for the CIE to recognise this. This means that much more information about the spread of fire within a zone can be obtained. Because of the communication techniques involved, the detectors do not have to be arranged on the circuit in address order, hence circuit wiring can take the most economical route. This method obviates the necessity of accurate installation drawings.

4.2.2 Detectors and Call Points

Addressable detectors and manual call points must conform to the same standards (i.e. the same BS EN) as conventional devices.

The removal of a detector on a circuit will not prevent the operation of any break glass call point. This is achieved in an addressable system because removal of a detector does not cause any break in the circuit. The removal of the detector is sensed by the absence of a 'reply' when the detector is polled by the CIE.

part one | guide to design of fire systems

which type of fire detection system

A contact monitor module is another device which can be used on an addressable system. This device is used for monitoring very simple items that provide a closing or opening volt free contact, for example a sprinkler flow valve.

4.2.3 Output Devices

Besides handling input devices, that is, detectors and call points, addressable systems can also handle output devices on the addressable loop. This is possible because part of the address message from the control panel can be a command instruction to an output device, signalling it to turn its output ON or OFF. A typical application of this would be a sounder module used to drive a number of sounders (or bells), or a plant interface module used to shut down a piece of electrical plant. All command instructions sent to output devices are ignored by input devices on the circuit (see Figure 5).

It is also acceptable to connect interface modules to conventional circuits. These modules allow conventional detectors on spur detector circuits to be connected to an addressable zone circuit and monitor the status of typically 20 conventional detectors. The conventional detectors on the spur communicate with the interface module and should any detector go into

alarm, the interface module signals to the control panel that an alarm condition has occurred. These modules are also often used to upgrade old conventional systems, by utilising the existing wiring, although new wiring should always be used where possible.

In order to provide short circuit protection and comply with the requirements of the code, isolators must be fitted at appropriate positions on an addressable loop (see Section 3.4).

part one | guide to design of fire systems

which type of fire detection system

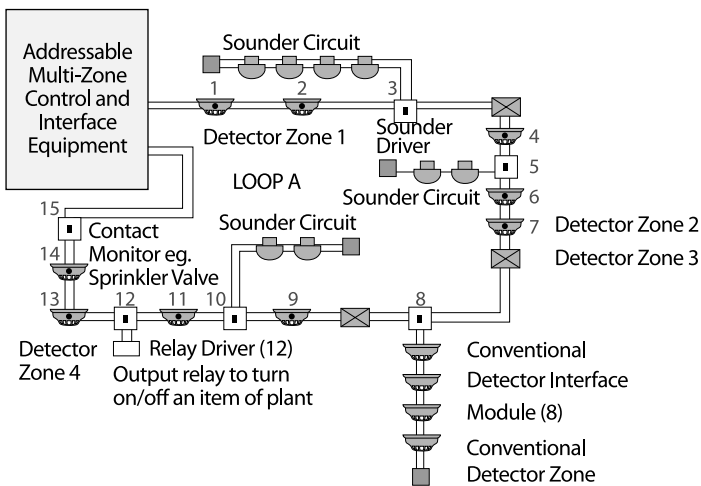

Note: Devices at addresses 3, 5, 8, 10 and 12 require a 24V d.c. supply to power the sounders (or bells) and detectors. This can be achieved by using addressable (and therefore monitored) remote power supply units

Key:

- Conventional Detector or Call Point
- Addressable Detector or Call Point
- Addressable Input or Output Command Module
- Sounder
- Line Isolator Module
- End of Line Device

fig 5. Addressable Loop System Circuit with Conventional Spur and Addressable Output Modules

part one | guide to design of fire systems

which type of fire detection system

4.3 Analogue Addressable Systems

In practice, all addressable systems are of the analogue type. An analogue addressable system is one which uses analogue addressable detectors, each of which give an output signal representing the value of the sensed phenomenon. The output signal may be a truly analogue signal or a digitally encoded equivalent of the sensed value. The decision as to whether the signal represents a fire or not is made at the CIE.

Apart from the way in which analogue addressable detectors operate, and the CIE communication principles employed, all system design elements of addressable systems (see Section 4.2) also apply to analogue addressable systems.

Conventional and two state addressable detectors can signal only two output states, normal and fire alarm.

Consequently, with these detectors it is impossible to ever establish how close the device is to an alarm condition, or whether the localised environmental conditions (which probably contain dust and dirt) are causing deteriorating changes in the detector's sensitivity, thereby adversely affecting its performance. However, an analogue addressable system can offer

a number of system performance improvements over both conventional and simple (non-analogue) addressable type systems, details of which are highlighted in the following subsections.

4.3.1 Operation of Analogue Addressable Detectors

The output of an analogue addressable detector is variable and is a proportional representation of the sensed effect of fire, that is smoke, heat, carbon monoxide or flame (see Figure 6). Transmission of this output from the detector is usually in the form of an analogue current. When the detector is interrogated or addressed by the control panel, the analogue detector responds with an analogue value rather than a status value as in the case of conventional detectors. In an analogue addressable system therefore, the analogue addressable detectors are simply acting as transducers which relay information (back to the control panel) concerning temperature, smoke density, etc. Microprocessor based circuitry in the control panel interprets the analogue value received and decides whether or not to indicate an alarm, pre-alarm, normal or fault condition.

In order that the system raises an alarm in the event of a fire, the analogue va-

part one | guide to design of fire systems

which type of fire detection system

lue output from the detector must be in the alarm condition (that is, above the alarm threshold) for a period equal to the time taken to complete three successive address sequences, typically fifteen seconds. This technique of scanning the sensor three times before raising an alarm is a useful way of helping to reduce false alarms from short term electrical or physical tran-

sients, without causing an excessive delay in actual alarm transmission.

As the output from each detector is an analogue value, the alarm threshold level can be controlled (or set) by software within the CIE. This software is usually stored in non-volatile memory (EEPROM) when the system is being configured during installation.

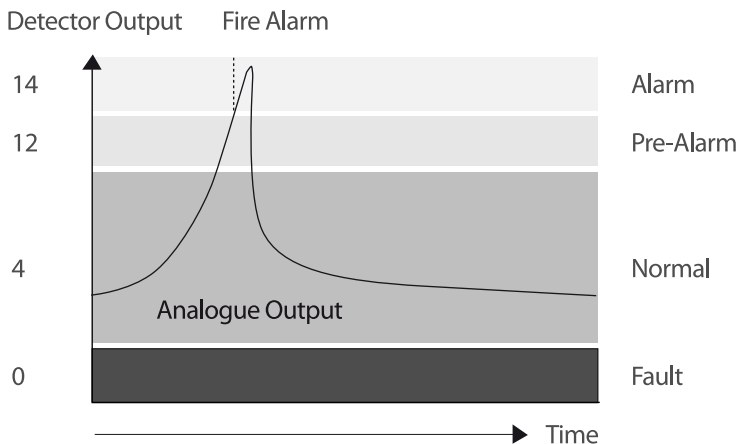

fig 6. Graph showing Analogue Current of an Analogue Detector Responding to a Fire

part one | guide to design of fire systems

which type of fire detection system

4.3.1.1 Detector Pre-Alarm Warning

Quite often in the early stages of a smouldering fire there is a slow build up of smoke before open burning takes place. With an analogue addressable smoke detector, the analogue value rises as the smoke builds up in the detector's sampling chamber. At a certain threshold level, that is the pre-alarm level (see Figure 7), the control panel can give a visual indication and audible

warning of this pre-alarm condition before a full-scale evacuation of the building is required and before the fire service are called. This situation allows the possible cause of the pre-alarm to be investigated prior to a full alarm condition. It also allows for primary fire fighting procedures (using portable extinguishers) to be put into effect. The pre-alarm signal also provides an opportunity to filter out false alarms.

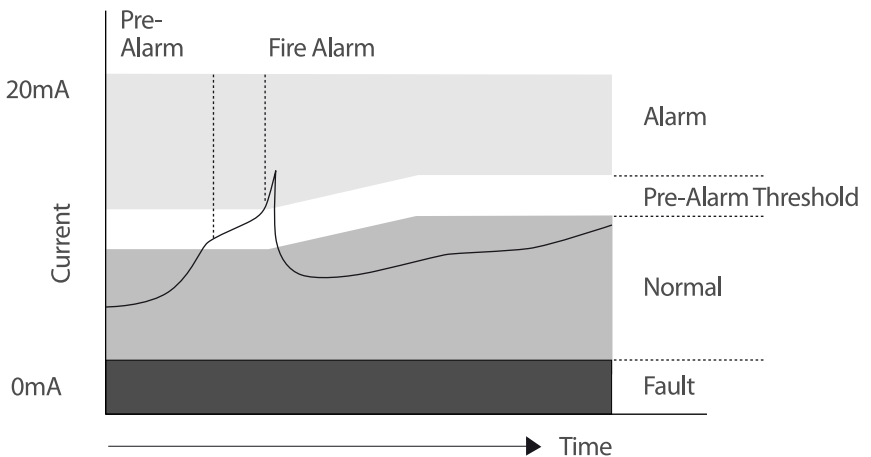

fig 7. Analogue Addressable Detector Typical Pre-Alarm Threshold Level

part one | guide to design of fire systems

which type of fire detection system

4.3.1.2 Detector Alarm Threshold Compensation

As detectors age and become contaminated with dust and dirt their performance begins to deteriorate such that their potential to go into an alarm condition is that much higher, thus resulting in false alarms. The nuisance factor caused by false alarms is a serious problem for users and fire services alike.

Since the output analogue value of each detector is continually checked by the control panel, the slow build up of conta-

minants in the detector is reflected by a slow increase in the analogue value. As this occurs, the control panel can alter the alarm (and pre-alarm) threshold in order to compensate for this phenomenon (see Figure 8).

This feature maintains the system at an optimum performance level and extends the life of each analogue addressable detector.

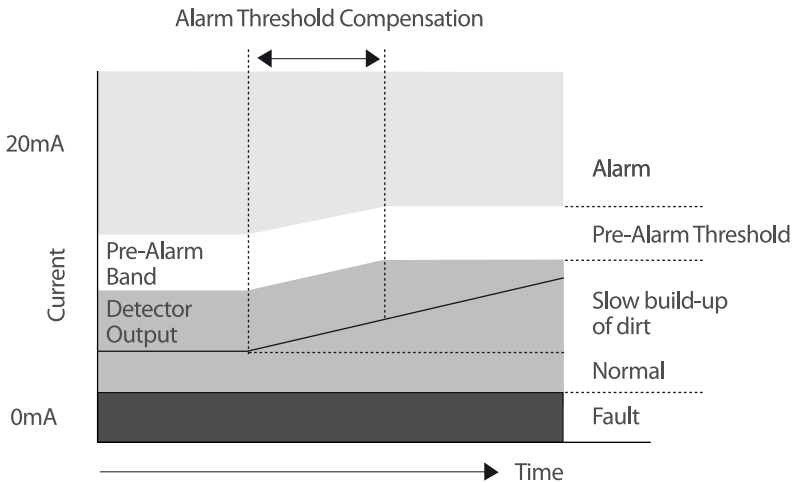

fig 8. Analogue Addressable Detector Alarm Threshold Compensation

part one | guide to design of fire systems

which type of fire detection system

The threshold compensation is not adjusted every time there is a minor fluctuation in the detectors sampling chamber. However, the control panel does take an average of the analogue value over the preceding hour and alters the threshold level accordingly.

4.3.1.3 Detector Condition Monitoring

In accordance with the threshold compensation (see subsection 4.3.1.2), there comes a time in the life of a detector when threshold compensation can no longer

be applied due to the dynamic range of the analogue signal. When this occurs, the control panel senses that the detector has reached the end of its operational life, and indicates a detector condition monitoring fault.

When a detector condition monitor fault is indicated, the detector must be replaced by a new one and the threshold compensation for the detector's address is automatically reset. Typically this point will only be reached after several years of operation.

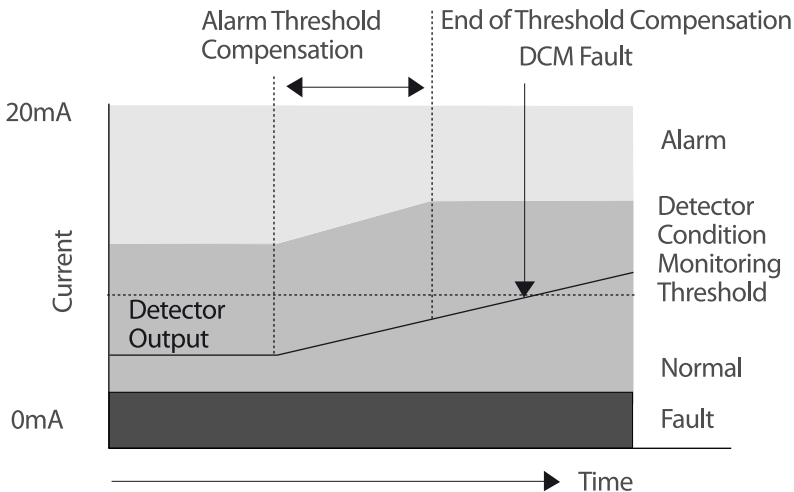

fig 9. Analogue Addressable Detector Condition Monitoring Threshold

which type of fire detection system

4.3.1.4 Detector Sensitivity Setting

Unlike conventional or addressable fire detectors where the sensitivity is fixed, each analogue addressable detector can be made to emulate a normal, low or high sensitivity smoke detector by simply selecting the appropriate threshold settings for each address in the software configuration at the CIE. Likewise, the sensitivity of heat detection can be selected in the software configuration at the CIE.

The option of being able to change the sensitivity settings of detectors can be useful in many situations. For example, at certain times of the day when the building is occu-

pled you might want to reduce the sensitivity level of detectors in selected zones. This feature allows the settings to be manually switched to low sensitivity for those zones and then switched back to normal sensitivity when the premises are again unoccupied (see Figure 10). There may be many reasons why you might want to do this, one being that you want to reduce the possibility of a false alarm occurring during the working day, but you want full protection at all other times.

The choice of alarm level sensitivities, plus any time delay which may be deliberately introduced, determine the overall system response to fire conditions. The alarm level

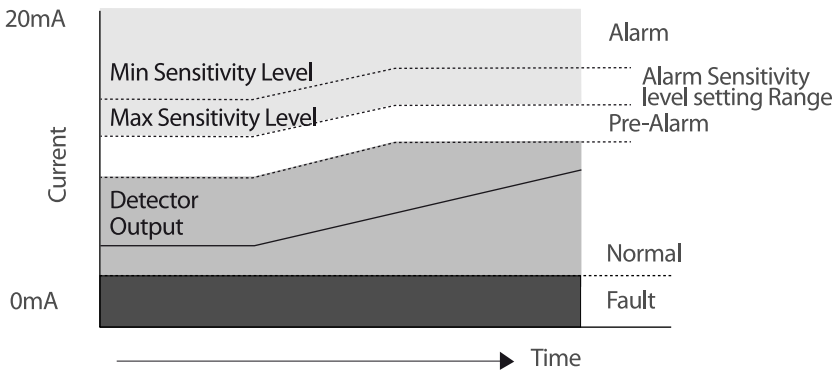

fig 10. Analogue Addressable Detector Alarm Sensitivity Level Setting Range

part one | guide to design of fire systems

which type of fire detection system

and time delay can in theory be allocated any value, but in practice the sensitivity range must be within the limits necessary to ensure compliance with the relevant part of BS EN 54.

When you have determined the type of fire detection and alarm system to use in the building, that is, conventional or analogue addressable, the next step in the design process is to decide which type of detectors should be used in the different areas (zones) to be protected, see section 5 (Detector Suitability).

detector suitability

5. Detector Suitability

Once you have decided upon the type of fire detection and alarm system to use in the building, that is conventional, addressable or analogue addressable, you now need to choose which type of detectors are to be used to protect the different areas within the premises.

There are several types of detector spread across the range, each of which responds to a different product of combustion (smoke, heat, etc.). Manual call points are used to provide a means for people in the building to raise the alarm.

The different detector types available are as follows:

- Multisensor
- High Performance Optical Smoke Detector
- Ion Chamber Smoke Detector
- Optical Smoke Detector
- Infra-Red Flame Detector
- Optical Beam Detector
- Aspirating Detector
- Linear Heat Detector
- Duct Probe Unit

5.1 General Fire System Engineering Principles

As each type of detector responds to a particular fire product, the relative speed of response of the detectors is therefore dependent upon the type of fire being detected. As smoke is normally present at an early stage in most fires, smoke detectors (Ion Chamber, Optical, High Performance Optical or Multi-sensor) are considered the most useful type available for giving early warning.

Most fires, in their later stages, emit detectable levels of heat. Therefore in areas where rapid fire spread is unlikely and environmental conditions preclude the use of smoke detectors, heat detectors (Rate of Rise or Fixed Temperature) are a general purpose alternative, but these should not be used in the escape routes of a Category L system.

Fires tend to produce carbon monoxide, particularly in situations in which there is insufficient ventilation to enable fire to burn rapidly. Accordingly, carbon monoxide fire detectors provide useful warning of such fires. The carbon monoxide fire detector is well suited to provide early warning of slow smouldering fires. Slowly developing and

part one | guide to design of fire systems

detector suitability

smouldering fires produce large quantities of carbon monoxide before detectable smoke aerosols and particulates reach smoke detectors in sufficient quantities to detect the fire. These detectors can often be used in applications in which heat detectors are insufficiently sensitive, but smoke detectors may cause false alarms from sources such as steam from a shower or smoke from burnt toast.

In situations where a burning liquid, for example alcohol, paint thinner, etc. is likely to be the prime source of a fire, and flame is most likely to be the first indication a fire has started, then an Infra-Red Flame detector should be incorporated into the system.

Although heat, smoke and carbon monoxide detectors are suitable for use inside most buildings, flame detectors may be used to supplement these where necessary. Flame detectors need an unobstructed line of sight, their greatest use being for such special applications as the supervision of an outdoor storage area or an area where petrochemical processes are taking place, for example offshore oil platforms. Infra-red flame detection can also be used to protect very high spaces, such as cathe-

drals, where the height is such that point smoke detectors cannot be used.

Also available are specialised detectors which have been specifically designed for use in applications where point and line-type detectors cannot be used. Two types are available, namely the Aspirating detector and Duct Probe Unit.

The Aspirating type detector comprises a small pump which draws a sample of air through holes in a pipe that is connected into a detector element. The detector element of the Aspirating detector is usually very much more sensitive than conventional point detectors to allow for the effects of dilution of smoke. This type of detector is normally used for protecting such areas as computer suites, clean rooms, or the interior of historic buildings where point or line-type detectors would look out of place. For further information also see subsection 5.2.6.

The Duct Probe Unit has been designed for use in situations where smoke, heat and flame type detectors cannot be used. It is primarily used for detecting the presence of smoke or combustion products in ventilation ducting systems. The detector has a small probe which protrudes into the duct and draws air from

detector suitability

the duct into the detector. For further information also see subsection 5.2.7.

5.2 Detector Selection for a Particular Area

The ability of any particular detector to respond to the various types of fire within different types of environment depends upon a number of factors, such as the operating principle, the sensitivity of the detector and the type of fire that occurs (e.g. smouldering or flaming).

The decision as to whether the detector is conventional or analogue addressable is a separate issue because the principle of the detection method remains the same. The dirtier the environment is, the more preferable the analogue addressable system becomes. Also the more cellular the space within a building is, the more preferable the addressability of analogue systems becomes.

In planning and designing the fire system, you may find the detector suitability selection chart shown in Table 1 below useful in determining the detector type(s) best suited for the specific environment into which the system is to be installed.

5.2.1 Smoke Detectors

To understand exactly how smoke detectors operate, you first need to know a little about the composition of smoke. Most fires produce smoke from their earliest stages, but the density and colour of the smoke depends very much upon the material that is burning and the conditions of combustion.

The differences between various types of smoke are caused by the variation in the size of the particles that make up the smoke. As a general rule, the hotter the fire the greater the number of very small (invisible) smoke particles. Conversely, a fire with low temperature decomposition produces proportionally more larger (visible) smoke particles.

Ion Chamber Smoke Detectors: These detectors respond very quickly to smoke composed of very small particles (even those invisible to the naked eye). However, they are less sensitive to the dense smoke composed of large particles. The detectors contain a small radioactive source which ionises the air within the sampling chamber. This causes a small current to be established. When smoke particles are introduced into the sampling chamber,

part one | guide to design of fire systems

detector suitability

Environment	Very Clean and Dry	Benign Moderately Clean Regulated Temperature	Dirty - Smoky During the Day	Dusty and/or Humid	Hot and Smoky When in Use	Open Areas
For Example	Clean Room Data Processing Suite	Offices Light Industrial Hospitals Residential Passenger Cabin	Loading Bay/ Warehouse with Diesel, Forklifts etc Heavy Industrial Ferry (Car Deck)	Livestock Pen Mill, Laundry Changing Room	Kitchen Engine Room Test Beds	Atrium Theatre Hanger Oil Rigs Turbine Hall
Fire Loading	Type	Type	Type	Type	Type	Type
Electronic Equipment Electrical Switchgear Electric Motors Cable Conduit	800PH 800I Aspirated	800PH 800I	800PH		800PH	S271f+
Fabrics, Clothes Soft Furnishings Paper, Cardboard Plastic Foams Animal Bedding Wood Shavings etc		800PH 800PH	800PH 800PH	800PH 800PH	800CH	800PH Beam
Flammable Liquids Paints Solvents Flammable Gasses Unstable Chemicals	800PH 800CH 800I S271f+	800PH 800CH 800I S271f+	800CH 800I 800H S271f+	800CH 800H S271f+	800PH 800H S271f+	S271f+
Foodstuffs General Org. Waste Animal Fodder Wooden Structures Solid Fuels		800CH 800PH	800CH 800PH 800H	800CH 800PH 800H	800CH 800H	800CH S271f+
Plastics Chemicals Machinery Building Materials Unknown Contents	800CH 800PH Aspirated	800PH 800CH 800I 800H Aspirated	800PH 800PH 800I 800H S271f+	800PH 800PH S271f+	800PH 800H	800PH S271f+

Bold text indicates most likely detector/mode to meet users' requirements

table 1. Detector Suitability Selection Chart

part one | guide to design of fire systems

detector suitability

ions are absorbed onto the surface of the particles, resulting in a reduction in the current.

The magnitude of this reduction in current provides an indication of the number of smoke particles. If the reduction in current exceeds a preset level, the detector signals an alarm condition to the control equipment.

Optical Smoke Detectors: These detectors respond quickly to large smoke particles but are less sensitive to small particles that do not constitute visible smoke. They detect the visible particles produced in fire by using the light scattering properties of the particles.

The detectors comprise an optical system which consists of an emitter and a sensor, each of which have a lens in front, and are

Designation Test Fire	Type of fire	Heat developed	Type of smoke	Test response				
				Ion Chamber	Optical	HPO	Multi-sensor (triple technologies)	Heat-enhanced CO
				801I	813P	801PH	801PC	801CH
TF1	Open cellulose	Strong	Dark visible	N	N	C	C	N
TF2	Smouldering (wood)	Minimal	Light visible	C	C	C	C	C
TF3	Glowing smouldering (cotton)	Minimal	Light visible	C	C	C	C	C
TF4	Flaming plastics (polyurethane foam)	Strong	Very dark visible	C	C	C	C	C
TF5	Liquid (N-heptane)	Strong	Very dark visible	C	C	C	C	C
TF6	Liquid (Methylated spirit)	Strong	None	N	N	N	N	N

table2. provides an indication of the response to BS EN 54 test fires that can be expected from the three different types of smoke detector.

The latest edition of the European smoke detector standard, EN 54-7 no longer awards sensitivity response classifications to smoke detectors. The detectors are either classified as a pass, C or not classified, N.

It should be noted that in the case of test fire 6 (TF6), smoke detectors are not expected to pass this test since no smoke or significant level of carbon monoxide is developed. BS EN 54-7 or BS ISO 7240-8 do not require that.

part one | guide to design of fire systems

detector suitability

so arranged that their optical axes cross in the sampling chamber. The emitter produces a beam of light which is prevented from reaching the sensor by a baffle.

When smoke is present in the sampling chamber, a proportion of the light is scattered and some reaches the sensor. The light that reaches the sensor is proportional to the smoke density.

High Performance Optical (HPO) Smoke Detectors: HPO detectors respond to smoke in the same way as standard optical detectors, but, when there is a rapid rate of rise in temperature, their sensitivity is increased so that they also respond to very small smoke particles, more like the Ion Chamber type detectors.

5.2.2 Heat Detectors

Heat detectors are normally used where the speed of operation of smoke detectors is not required or where, for environmental or other such reasons, smoke detectors cannot be used in the system. In such circumstances, heat detectors can provide an acceptable, though less sensitive alternative. Three types are available. These are the Rate of Rise detector, the Fixed Temperature detector and the Line Type detector. Careful consideration should be given to

the type of heat detectors that are to be used in certain areas. Rate of Rise type detectors, for example, should not be used in areas where large sudden changes in temperature are normal (such as in a kitchen), otherwise false alarms will occur.

The upper limit response times for the different types of heat detectors, as prescribed in BS EN 54-5, are shown in Table 4. It should be noted that Class A1 heat detectors are more sensitive (and hence will respond quicker) than Class A2 detectors. For this reason, Class A1 detectors can be used at a greater ceiling height than Class A2 detectors (see Section 6). Class B - G detectors are only used where the ambient temperature is higher than normal.

Rate of Rise Heat Detectors Of the three heat detector types available, these are the preferred type. These detectors react to abnormally high rates of change of temperature and provide the fastest response over a wide range of ambient temperatures. A fixed temperature limit is also incorporated in these detectors. These detectors are ideally suitable for use in areas where a large change in ambient temperature is likely to occur by the stage at which it is necessary to detect a fire.

part one | guide to design of fire systems

detector suitability

ENVIRONMENT	VERY CLEAN AND DRY		BENIGN MODERATELY CLEAN REGULATED TEMPERATURE			DIRTY-SMOKY DURING THE DAY			DUSTY AND/OR HUMID		HOT AND SMOKY WHEN IN USE		OPEN AREAS	
FOR EXAMPLE	CLEAN ROOM DATA PROCESSING SUITE		OFFICES, HOSPITALS, LIGHT INDUSTRIAL, RESIDENTIAL, PASSENGER CABIN			WAREHOUSE WITH DIESEL FORK-LIFTS etc. HEAVY INDUSTRIAL FERRY (CAR DECK)			LIVESTOCK PEN MILL, LAUNDRY, CHANGING ROOM		KITCHEN ENGINE ROOM, TEST BEDS		ATRIUM, THEATRE HANGER, OIL RIGS TURBINE HALL	
FIRE LOADING	Toxic Gas	MODE Night Day	Toxic Gas	MODE Night Day		Toxic Gas	MODE Night Day		Toxic Gas	MODE Night Day		Toxic Gas	MODE Night Day	
ELECTRONIC EQUIPMENT ELECTRICAL SWITCHGEAR ELECTRIC MOTORS CABLE CONDUIT	N/A	0 0 1 1 3 3	N/A	0 1 3	0 1 3	0 1 3	0 1 3	1 0 3	N/A	0 1 1 0 3 3	N/A	0 1 1 0 3 3	N/A	0 0 1 1 4 4
FABRICS CLOTHES SOFT FURNISHINGS PAPER, CARDBOARD PLASTIC FOAMS ANIMAL BEDDING WOOD SHAVINGS etc.	(3 + 5)	0 0 1 1 3 3 4 4	(3 + 5)	0 1 3 4	0 1 3 4	(3 + 5)	0 1 3 4	1 0 4 4	N/A	0 1 1 0 4 4	(2 + 5)	1 1 1 1 4 4	N/A	0 0 1 1 4 4
FLAMMABLE LIQUIDS PAINTS SOLVENTS FLAMMABLE GASSES UNSTABLE CHEMICALS	(3 + 5)	0 0 1 1 3 3	(3 + 5)	0 1 3	0 1 3	(3 + 5)	1 2 4	2 1 4	(4 + 6)	1 2 2 1 4 4	(3 + 6)	1 1 1 1 4 4	N/A	0 0 1 1 4 4
FOODSTUFFS GENERAL ORGANIC WASTE ANIMAL FOODER WOODEN STRUCTURES SOLID FUELS	(3 + 5)	0 1 1 0 3 3 4 4	(3 + 5)	0 1 3 4	1 0 3 4	(3 + 5)	0 1 3 4	1 0 4 4	N/A	0 1 1 0 4 4	(2 + 5)	1 1 1 1 4 4	N/A	0 0 1 1 4 4
PLASTIC CHEMICALS MACHINERY BUILDING MATERIALS	(3 + 5)	0 1 1 0 3 3 4 4	(3 + 5)	0 1 3 4	1 0 3 4	(3 + 5)	0 1 3 4	1 0 3 4	(3 + 5)	0 1 1 0 3 3 4 4	N/A	1 1 1 1 4 4	N/A	0 0 1 1 4 4

Mode 0 - Universal
Mode 1 - High Resilience
Mode 2 - Heat R - o - R
Mode 3 - HPO
Mode 4 - CCO
Mode 5 - Gas

Bold text indicates most likely detector/ mode to meet user's requirements.
Letters in brackets represent possible options if gas detection is required.

Table is for guidelines only and specific situations are likely to require variations on the suggested detector types. Customer knowledge of relative impact of false alarm vs undetected fires should be considered. Night and Day columns represent low false alarm risk and high false alarm risk, although this usually follows a day/ night pattern, it may be configured for any time. For example the car deck of a ferry would be configured for Day during vehicle loading and Night once all the passengers had left the car deck, thus achieving optimum protection for that area.

table3. Selection chart for Multi-sensor detectors (801PC)

Multi-sensor detectors integrate optical smoke, carbon monoxide (CO) and heat sensors. They use all three sensing methods to deliver early fire detection and false alarm resistance. Sophisticated algorithms analyze smoke, gas and heat to distinguish real fires from other false alarms causing culprits like steam from showers and burnt toast. Tyco multi-sensor detector 801PC has 6 selectable modes of operation. Table 2 gives guidelines for mode selection in specific situations.

part one | guide to design of fire systems

detector suitability

Fixed Temperature (Static) Heat Detectors

These detectors are similar to the Rate of Rise type detectors except that they react at a pre-determined temperature rather than a rate of rise temperature. These detectors are ideally suitable for use in areas where sudden large changes in temperatures are considered normal, for example in kitchens and boiler rooms.

Line-Type Heat Detectors

These detectors are not commonly used, but nevertheless, they are another type that are available. Point-type detectors, such as the Rate of Rise and Fixed Temperature types are about the size of a teacup and are designed to sense the conditions near a fixed point. Line-Type detectors, however, come in the form of a long wire or tube, and are designed to sense the conditions in the vicinity of the line. They are ideally suited for such applications as cable tunnels, cable trays and risers, high rack storage areas, transformer bays, thatched roofs, building services, subways and ducts, aircraft hangers, etc. Two versions are available, non-integrating and integrating.

The non-integrating Line-Type heat detector usually consists of an electric cable, with insulation of fixed melting point, which is suspended over the area to be protected. If one small section of the wire is heated up

(due to fire) and the temperature of the section is greater than or equal to the melting point of the wire, the melting of the insulation results in a short circuit and causes the system to go into alarm.

The integrating Line-Type heat detector is similar to the non-integrating version except here the insulation does not melt. Its electrical resistance is temperature dependent. In effect, the average temperature is taken over the whole length of the wire rather than just sections of it. Consequently, a large amount of heat in a small area would need to be generated in order to create an alarm.

To allow for easy location of alarm or fault conditions, it is recommended that the maximum length of the sensing wire used with Line-Type detectors be limited to 200 metres. Lengths of up to 500 metres are available for special requirements. High resistance sensor wire is also available for use in areas with high ambient temperatures, that is, temperatures greater than 50 °C.

5.2.3 Heat-enhanced Carbon Monoxide Fire Detectors

Heat-enhanced carbon monoxide fire detectors use an electrochemical cell to detect

part one | guide to design of fire systems

detector suitability

Rate of Rise of Air Temperature	Class A1 (mins, seconds)	Class A2 or Classes B - G (mins, seconds)
30°C/min	1, 40	2, 25
20°C/min	2, 20	3, 13
10°C/min	4, 20	5, 30
5°C/min	8, 20	10, 0
3°C/min	13, 40	16, 0
1°C/min	40, 20	46, 0
Maximum Static response temperature	65°C	70 - 160°C depending on class
Max. Ambient Temp.	50°C	50° - 140°, depending on class

table4. Upper limit response times for heat detectors

the build up of carbon monoxide generated by fires. The cell operates by oxidizing carbon monoxide on a platinum sensing electrode. Within the electrochemical cell the ions produced by this reaction result in a

current flow between electrodes. The electrical output of the cell is directly proportional to the carbon monoxide concentration. The performance of the detector is relatively unaffected by changes in temperature,

part one | guide to design of fire systems

detector suitability

pressure or airflow. The electrochemical cell typically has a life of around five years, after which it should be replaced.

Tyco heat-enhanced carbon monoxide fire detector can be set in an analogue system to provide high, normal and low sensitivity.

When set to normal sensitivity, an alarm signal will be given at a carbon monoxide concentration of 40 parts per million. For comparison purposes, background carbon monoxide levels generally remain well below 10 parts per million, with excursions of up to around 15 parts per million under unusual atmospheric conditions. Even in rooms with heavy smokers, or close to a source of air pollution, ambient levels of carbon monoxide generally remain below the 40 parts per million level at which a carbon monoxide fire detector operating at normal sensitivity will give an alarm signal.

Although, in the areas that BS 5839-1 accepts the use of carbon monoxide fire detectors, the detectors should be sited and spaced following the same recommendations as applicable to smoke detectors, in practice, carbon monoxide detectors are likely to be more tolerant of position relative to the seat of the fire, than smoke detectors.

As carbon monoxide is a gas, it diffuses to create a uniform concentration within the space in which it is generated. Thus, it is likely that carbon monoxide fire detectors will be less affected by obstructions and heat barriers than smoke detectors. In addition, carbon monoxide fire detectors in corridors may detect fire in an adjacent room before a smoke detector in the corridor, as carbon monoxide will diffuse evenly throughout the corridor, whereas smoke will tend to cool to an extent that there is insufficient buoyancy to remain at the level at which smoke detectors are installed.

Heat-enhanced carbon monoxide fire detectors are particularly suitable for detecting smouldering fires and fires within confined spaces, such as bedrooms within a sleeping risk. In the latter application, carbon monoxide fire detectors will provide a higher standard of protection for sleeping occupants than heat detectors, but are less likely to produce false alarms than smoke detectors. The addition of a heat sensor to enhance the sensitivity of the carbon monoxide sensor enables heat-enhanced carbon monoxide detectors to respond to a wider spectrum of fires that generate heat as well as CO.

detector suitability

Carbon monoxide fire detectors are not suitable for fires that generate little or no carbon monoxide. Such fires include the early stages of electrical cable decomposition, where the HPO detector or aspirating fire detector is more suitable. Carbon monoxide fire detectors are also unsuitable for protection of areas where fast burning chemical fires represent the main hazard. In this case, ion chamber or flame detectors are more suitable.

Although heat-enhanced carbon monoxide fire detectors respond to BS EN 54-7 Test Fires, they do not detect smoke. It should be noted that these Test Fires do not represent all real fires, nor are they intended to do so. In particular, they tend not to produce carbon monoxide in the early stages of the fire. Real fires, particularly those of a smouldering nature, may actually produce carbon monoxide before they produce sufficient smoke of high enough temperature to operate smoke detectors.

5.2.4 Flame Detectors

Infra-Red flame detectors, unlike smoke and heat detectors, do not rely on convection current to transport the fire products to the detector, nor do they rely on a ceiling to trap the products. They detect electromagnetic radiation, which travels from a flame at the speed of light. They respond

only to the short wavelengths of very high temperatures such as that present in flames. The radiation from flames is characterised by a flicker at a frequency in the range of 5 to 30 cycles per second.

To safeguard against false alarms, these detectors have inbuilt features which inhibit them from responding to phenomena such as the long wavelength radiation given off by hot or over-heated bodies, or the steady radiation given off from hot objects where there is no fire (even if the radiation is of the same wavelength as that of a flame). They also contain circuitry to prevent false alarms from momentary effects. The flickering shortwave infra-red radiation must be maintained for a period of time (depending on its magnitude) before an alarm is given.

These detectors can be used to protect large open areas without sacrificing speed of response to flaming fires. In order to ensure full coverage however, flame sensors do require direct line of sight to all parts of the area to be protected.

The detectors are designed to respond rapidly to fires that involve clean burning fuels such as alcohol or methane, that is fires that would not be detected by the use of smoke detectors or carbon monoxide fire detectors (see Table 1).

part one | guide to design of fire systems

detector suitability

For flaming fires, flame sensors are probably the most sensitive. The sensitivity of flame detectors can vary considerably. Normally they should be able to detect a 15cm high flame at a range of between five and ten metres. They will detect a 0.1m² petrol fire at 27m on the centre line, within approximately 10 seconds. A 0.4 m² fire is detected at 47m. The flame height is roughly proportional to the range (see Figure 11).

As infra-red flame detectors cannot respond until there is flame, it is considered practical to also use smoke detectors or carbon monoxide fire detectors in conjunction with flame detectors in areas where the contents are likely to smoulder in the event of fire. In the case

of smouldering fires, smoke and carbon monoxide is very often produced long before flaming occurs. Consequently, the smoke or carbon monoxide detectors should cause the system to go into alarm before flaming can start. Conversely, if the contents are highly flammable, the flame detectors should cause the system to go into alarm before the smoke detectors or carbon monoxide detectors can detect the fire.

5.2.5 Optical Beam Detectors

Optical beam detectors must conform with the requirements of BS EN 54-12.

Optical beam detectors consist of two units, a Transmitter and a Receiver, which

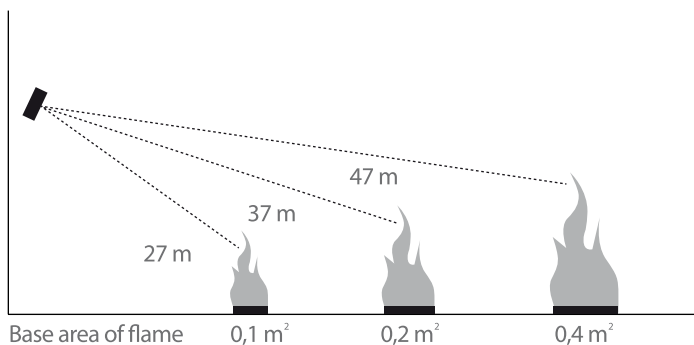

fig 11. Flame detector typical response characteristics (centre line range against petrol flames)

part one | guide to design of fire systems

detector suitability

are displaced some distance apart (10 metres to 100 metres).

Alternatively the transmitter and receiver are combined into a single unit and a reflector is used to bounce the transmitted beam back to the receiver.

This type of detector is specifically designed for interior use in large open-type areas, such as warehouses, manufacturing plants, aircraft hangers, workshops, etc. where the installation of point-type detectors would be difficult. They are also ideally suitable for installation in art galleries, cathedrals, etc. where, due to ornate and historic ceilings, point-type detectors and their associated wiring would be unsuitable.

During operation, the transmitter unit projects a modulated infra-red light beam di-

rectly at the receiver unit. The receiver unit converts the received light beam into a signal which is continuously monitored by the detector. If fire breaks out in an area protected by these detectors, smoke particles rising upward interrupt or partly deflect the light beam thus reducing the strength of beam received by the receiver unit (see Figures 12). If the signal in the receiver unit, which proportionally represents the strength of received light beam, is reduced by between 40 and 90 % for a period greater than five seconds (approximately), it causes the system to go into alarm.

For correct operation the transmitter and receiver units must be mounted in the roof space or just below the ceiling, whichever is applicable.

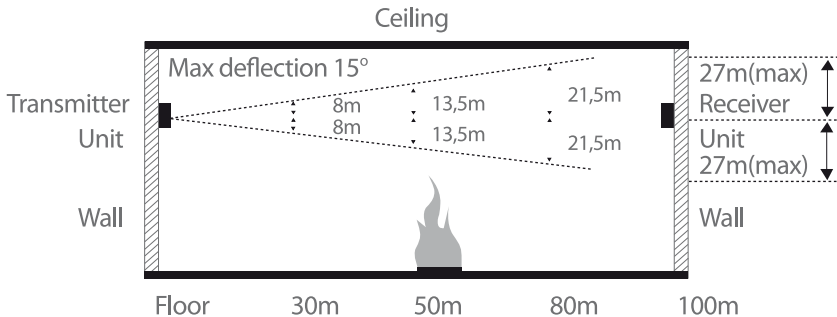

fig 12. Beam detector deflection characteristics (Vertical plane view)

part one | guide to design of fire systems

detector suitability

Each detector is capable of protecting an area 7.5 metres each side of the beam centre line for a distance of up to 100 metres, thus providing a total coverage of up to 1500 square metres (see Figure 13).

The transmitters and receivers shall be mounted on solid construction that will not be subject to movement, otherwise fault signals or false alarms can occur.

Sometimes in buildings with very high spaces, such as an atrium, optical beam detectors are mounted much lower than the highest point within the space. The reason for this is that, as the plume of smoke rises, it cools and will level out when it reaches ambient temperature. This effect, which is known as stratification, may occur well be-

low the highest point within a tall space, so seriously delaying operation of a detector at the highest point.

Unfortunately, it is never possible to predict exactly where stratification will occur. If the beam of an optical beam detector runs at a much lower level than that at which stratification does occur, the relatively narrow rising plume of smoke may by-pass the beam. For this reason, the low level beam detectors should only be regarded as supplementary to detection at the highest point in the space.

BS 5839-1: 2002 gives guidance on the siting of these supplementary beam detectors, taking into account that the plume does spread out as it rises. Accordingly, the

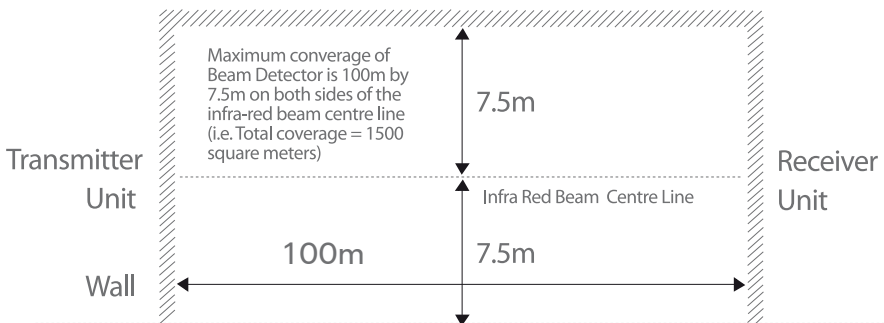

fig 13. Beam detector coverage characteristics (Horizontal Plane View)

part one | guide to design of fire systems

detector suitability

code recommends that the width of the area protected on each side of a supplementary optical beam should be regarded as 12.5% of the height of the beam above the highest likely seat of fire. For example, if the supplementary beam detectors were

mounted 10m above the base of an atrium, optical beam detectors would need to be sited every 2.5m across the width of the atrium (see Figure 14).

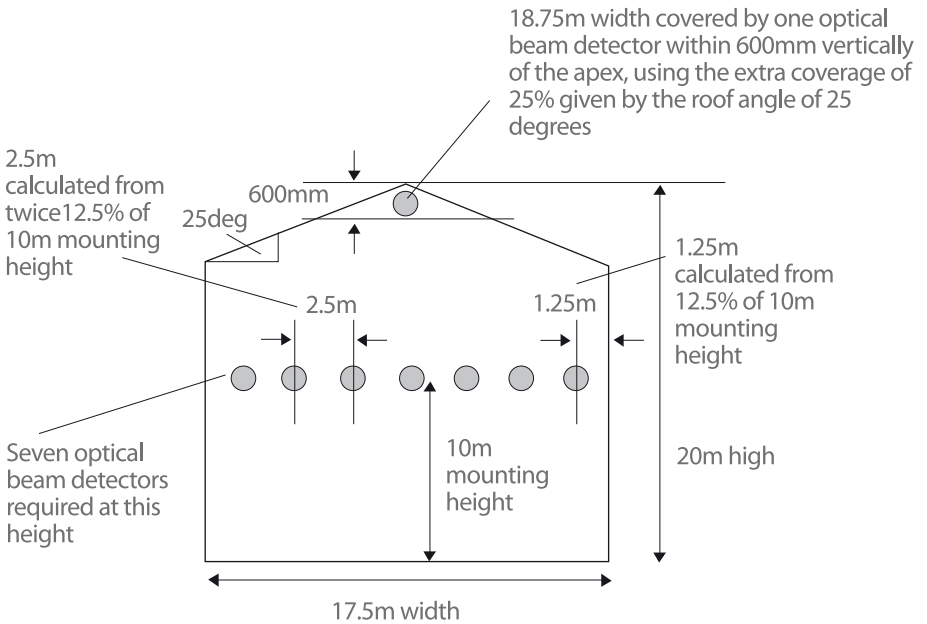

fig 14. Sitting of supplementary optical beam detectors

part one | guide to design of fire systems

detector suitability

5.2.6 Aspirating Detectors

Optical beam detectors must conform with the requirements of BS EN 54-20.

Aspirating detectors comprise a small pump which draws samples of the room air through holes in the system pipework into a detector element. The tube can be split into several smaller tubes (each drawing samples of air from different locations) or have several holes and through which air samples can be drawn (see Figure 15).

To allow for the effects of dilution of smoke, the detector element of an aspirating de-

tor is usually up to 100 times more sensitive than that of conventional point and line-type detectors. The air being sampled is often passed through a filter before being analysed for the presence of smoke.

The detector provides a number of outputs, each of which relate to a different density of smoke contained in the air being sampled. It is normal practice to monitor at least two outputs from each detector. One can indicate that smoke is present in the air (30% of the detectors range), and the other that fire is present (60% of the detectors range). These outputs can be reported on separate zones of a conventional fire system control panel but it is more appropriate for the outputs to be connec-

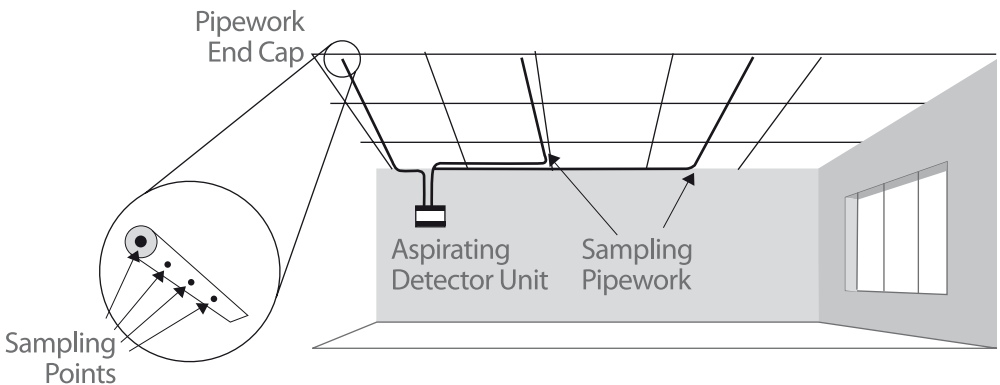

fig15. Aspirating detector ceiling mounted pipework

detector suitability

ted to two address points in an addressable fire system.

These detectors are particularly useful for protecting computer suites and clean rooms. The use of aspirating systems for this purpose is discussed in BS 6266. Commonly, in this situation, the aspirating system is not used to provide the general fire detection throughout the space (which often takes the form of normal point smoke detectors), but the system is used to monitor the return flow to air conditioning units in the protected space. The intention is to detect the very small amounts of combustion products transported within the conditioned air within the room. These are also used for the protection of historic buildings where point or line-type detectors would look out of place.

In this case, the pipework can be concealed above a ceiling, and small sampling tubes are dropped through small holes in the ceiling to provide virtually invisible fire detection.

The Fire Industry Association (FIA) publish a detailed code of practice for aspirating detection systems.

5.2.7 Duct Probe Unit

The duct probe unit is a detector which has been designed for use in situations where the standard smoke, heat and flame types cannot be used. Primarily, it is used for detecting the presence of smoke or combustion products in extract ventilation ducting systems. The detector operates in a similar way to aspirating detectors except it does not contain a pump. Instead, it is designed to operate on the venturi effect in the sampling pipe providing optimum airflow through the smoke detector. (see Figure 16).

The unit is especially recommended for installations in ducts with low airflow. The system fulfils all the requirements for safe fire detection with airflow speeds from 0,5 m/s to 20 m/s.

The length of the venturi pipe shall be chosen based upon how wide the ventilation duct is. The venturi pipe is available in 3 lengths; 0,6, 1,5 and 2,8 m. When the ventilation duct is wider than 0,6 m, the venturi pipe should penetrate the whole duct. The probe is flow direction sensitive and must be fitted accordingly. The air in the sampling chamber is analysed for the presence of smoke particles, and if found, the unit signals this condition to the control panel.

part one | guide to design of fire systems
detector suitability

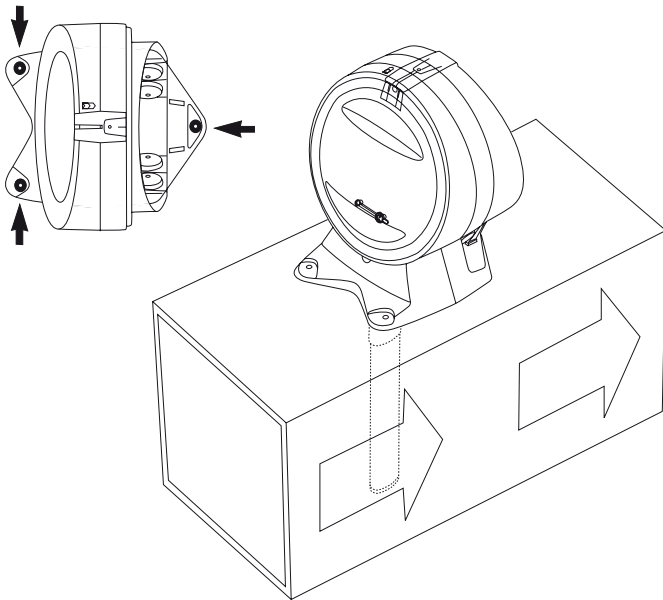

fig16. Duct probe unit installed in return air duct

detector coverage

6. Detector Coverage

Clause 22 of the code describes where detectors should be sited and what spacing should be used. Most of the recommendations of clause 22 are common for all Categories of system. In a few cases, however, a recommendation varies, according to the Category of system.

6.1 Spacing Under Flat Ceilings

In open spaces under flat horizontal ceilings, every point should lie within a horizontal distance of 7.5m from a smoke detector

or 5.3 m from a heat detector [22.3 a)]. In simple terms, this means that each point within the protected area must be covered by at least one detector; the coverage of a detector is a circle centred on the detector and having a radius of 7.5m for smoke detectors and 5.3 m for heat detectors. For beam detectors, the horizontal distance should be taken to the nearest point on the infra-red light beam, and the coverage should be taken as extending to that distance on both sides of the centre line of the beam see Figure 17 below).

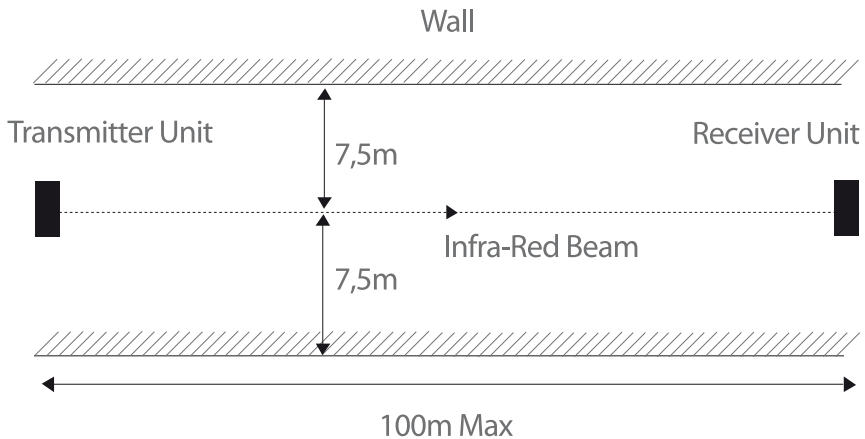

Beam Detector Spacing

part one | guide to design of fire systems

detector coverage

The sensitive elements of smoke detectors should normally lie within the range of 25mm to 600mm from the ceiling, and for heat detectors within the range of 25mm to 150mm.

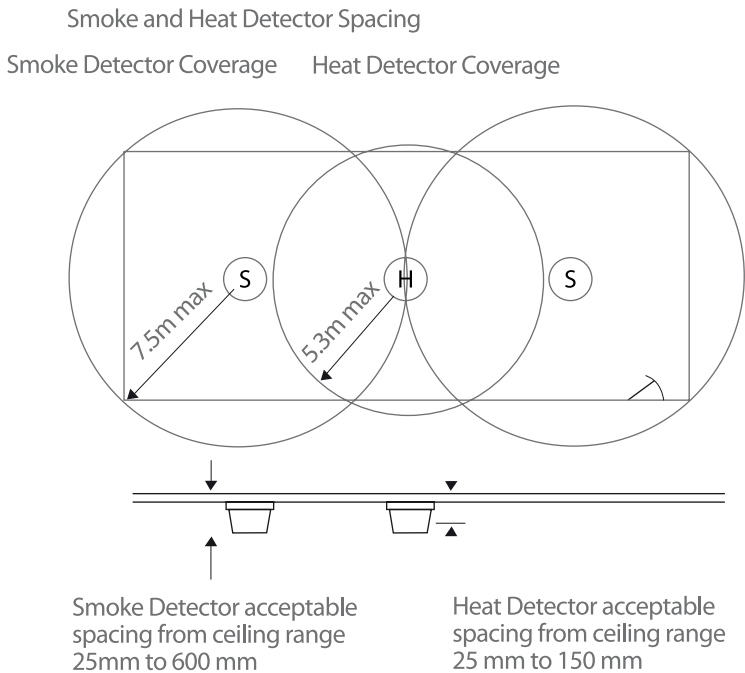

fig 17. Detector coverage and spacing under flat ceilings

detector coverage

6.2 Spacing Under Pitched Ceilings

If the ceiling is pitched, sloping or north-light, and the difference in height between any apex and an adjacent valley or low point of the ceiling exceeds 600mm for smoke detectors or 150mm for heat detectors, then detectors should be placed in or near the apex. (A detector may be regarded as 'near' the apex if the vertical distance from the apex to the detector

is not greater than the above figures.) If the differences are less than that quoted, then the ceiling can be considered as flat. For the row of detectors mounted in or near the apex, the radius of cover can be increased by 1% for each degree of slope up to a maximum of 25% [22.3 b)] (see Figure 18 below).

For a semi cylindrical arch or a hemispherical dome, the radius of cover of a de-

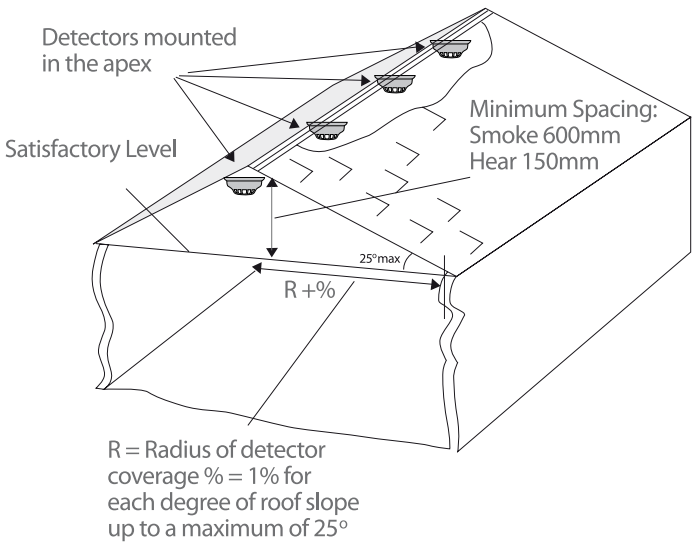

fig18. Detector coverage for pitched

part one | guide to design of fire systems

detector coverage

detector in the centre can be calculated as 8.93m for a smoke detector and 6.31m for a heat detector.

6.3 Spacing in Corridors

In the past, designers have often applied the recommendations for the maximum distance between any point and the nearest detector with unnecessary accuracy, so that, for example, the 7.5m dimension was deemed to be the maximum distance between any point on the ceiling adjacent to the wall of the corridor and the nearest detector. This led to unnecessarily complex tables for spacings between detectors in corridors, according to the corridor width.

Since fires do not constitute point sources and the plume of gases spreads as it rises, this approach is now regarded by BS 5839-1 as unnecessarily purist. Accordingly, in corridors of no more than 2m in width, the code considers only the distance between points close to the centre line of the corridor and the nearest detector. The effect of this is that, in these corridors, smoke detectors can be spaced 15m apart, while heat detectors (e.g. in a Category P system) can be spaced 10.6m apart. In corridors wider than 2m, the approach to detector spacing should be the same

as that adopted in other areas, namely that the maximum distance between any point (along the boundary wall of the corridor) and the nearest detector should be no more than 7.5m in the case of smoke detectors and 5.3m in the case of heat detectors.

6.4 Stairways

In enclosed stairways, fire detectors should be sited at the top of the stairway and on each main landing.

An open stairway forms a path for vertical spread of smoke and fire. It is desirable to detect products of combustion before they pass up the stairway and as they pass out of the stairway. For this reason, a fire detector should be sited at the top and, on each level, within approximately 1.5m of the floor penetration. This protection is, however, only required in the areas protected by the Category of system in question. It is not necessary in the case of a Category L4 system and may not be required in the case of a Category L5 or P2 system, although the designer should always consider the provision of these detectors in the latter two systems.

6.5 Lift Shafts and Other Flue-like Structures

Shafts for lifts, escalators or hoists, and any enclosed chutes, should be treated like open stairways. Thus, again, in areas protected by the Category of system in question, a detector should be sited at the top of the shaft or enclosure and, on each level, within approximately 1.5m of the penetration of the floor. Although not necessary in

a Category L4 system, this form of protection should be considered by the designer in the case of a Category L5 or P2 system, albeit that it may not always be necessary.

6.6 Obstructions

Ceiling obstructions, such as structural beams, deeper than 10% of the overall ceiling height should be treated as walls. The area on each side of the obstruction

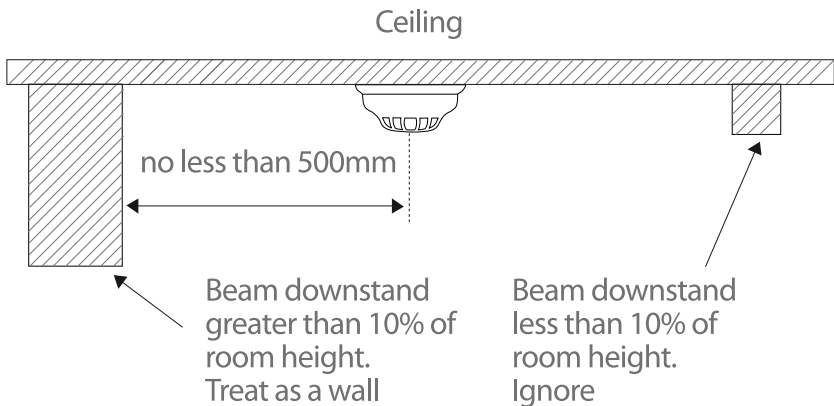

fig 19. Ceiling Obstructions Treated as Walls

part one | guide to design of fire systems

detector coverage

should, therefore, be regarded as a separate area for the purpose of protection. The same applies in the case of partitions or storage racks that extend within 300mm of the ceiling (See Figures 19 and 20).

Where structural beams, ductwork, lighting fittings or other fixings to ceilings, not greater than 250mm in depth, create obstacles to the flow of smoke, detectors should not be mounted closer to the obstruction than twi-

ce the depth of the obstruction. (See Figure 21) Where obstructions, such as structural beams and ductwork, are greater than 250mm in depth, detectors should not be mounted within 500mm of the obstruction.

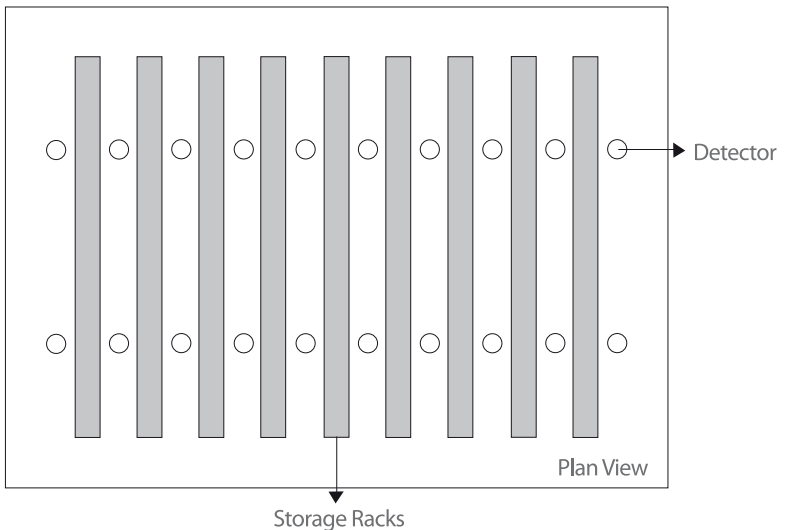

fig 20. Partitions or Storage on Racks

part one | guide to design of fire systems
detector coverage

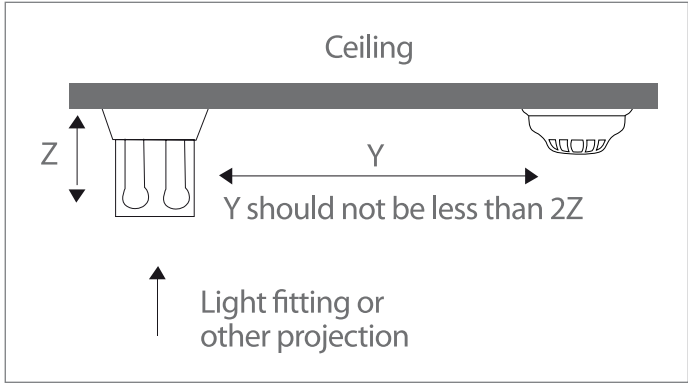

fig 21. Proximity of Detectors to Ceiling Fittings

6.7 Honeycomb Ceilings

Where a horizontal ceiling comprises a series of small cells, often referred to as a honeycomb ceiling, detector spacing and siting should be in accordance with Table 4. (See Figure 22).

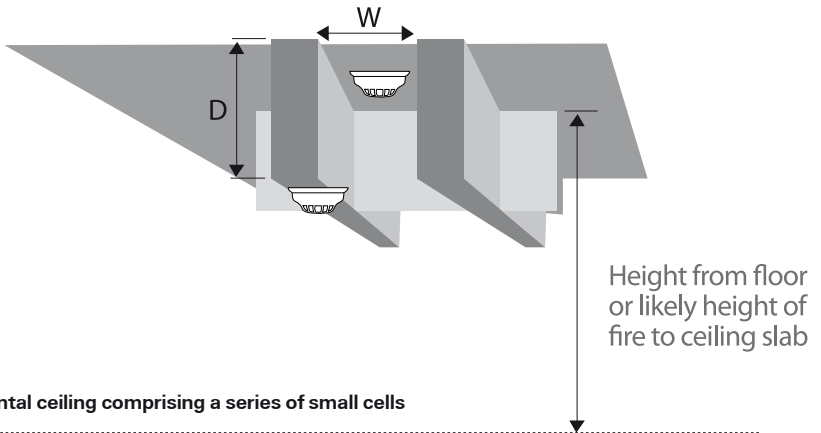

fig 22. Horizontal ceiling comprising a series of small cells

part one | guide to design of fire systems

detector coverage

Overall ceiling height from floor into cell (H) (to nearest whole metre)	Beam depth (D)	Maximum distance between any point and the nearest smoke (heat) detector	Detector location if W is 4D or less	Detector location if W is more than 4D
6m or less	less than 10%H	As per flat ceilings	Underside of beams	On structural slab in the cell
more than 6m	less than 10%H and 600mm or less	As per flat ceilings	Underside of beam	On structural slab in the cell
more than 6m	less than 10%H and more than 600mm	As per flat ceilings	Underside of beams ^a	On structural slab in the cell
3m or less	more than 10%H	4.5m (3m)	Underside of beams	On structural slab in the cell
4m	more than 10% H	5.5m (4m)	Underside of beams	On structural slab in the cell
5m	more than 10% H	6m (4.5m)	Underside of beams	On structural slab in the cell
6m or more	more than 10%H	6.5m (5m)	Underside of beams	On structural slab in the cell

KEY: W = Width of cell D= Depth of beams that form each cell

^a Since mounting detectors at a depth of more than 600mm below the highest point in the protected spaces does not comply with 22.3d, protection in these circumstances might need careful consideration to determine the most suitable location and spacing of detectors.

table 4. Spacing and Siting of Detectors

6.8 Closely Spaced Structural Beams and Floor Joists

Where there are a number of closely spaced structural beams, such as floor joists, a series of reservoirs for smoke, which BS 5839-1 refers to as 'cells', occur. Provided that the longer dimension of the cells is no more than L, then across the shorter cell dimension, the spacing, M, between detectors should be as given in Table 5. The spacing for the end detector to the end wall is half M. Detectors should be in the centre of

the cells. If the longer dimension of the cells is more than L (see below), then the cell should be stopped to the depth of the beam and at no more than L. If this is impractical, detection should be installed in every cell. See Figure 23.

L = 10.6m for smoke detectors.

L = 7.5m for heat detectors.

part one | guide to design of fire systems
 detector coverage

Overall ceiling height from floor to structural slab (to nearest whole metre)	Beam depth	Maximum distance between any two smoke (heat) detectors measured across the beams
H	D	M
6m or less	less than 10% H	5m (3.8m)
more than 6m	less than 10% H and 600mm or less	5m (3.8m)
more than 6m	less than 10% H and 600mm or less	5m (3.8m)
3m or less	more than 10% H	2.3m (1.5m)
4m	more than 10% H	2.8m (2m)
5m	more than 10% H	3m (2.3m)
6m or more	more than 10% H	3.3m (2.5m)

table5. Spacing and siting of detectors on ceilings with closely spaced structural beams or joists.

part one | guide to design of fire systems

detector coverage

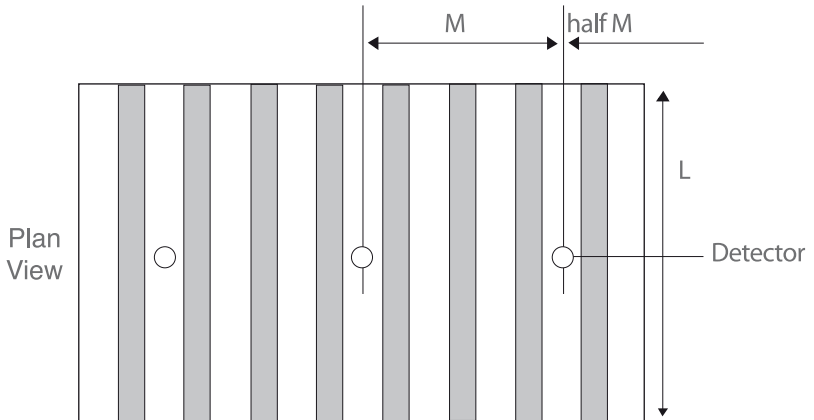

In this example beam downstands are greater than 10% of ceiling height, H . $H = 3\text{m}$. Smoke detectors are used in this example. Using table 5, the spacing, M should be no more 2.3m

fig 23. Cells formed from joists

6.9 Ceiling Heights

Detectors should not generally be mounted on ceilings higher than those listed under 'General Limits' in Table 6 below. However, if small sections of ceiling, not exceeding in total 10% of the ceiling area within the protected area, exceed these limits, these higher sections are adequately protected provided that the ceiling height does not exceed the limits in column two Table 6.

In the case of Category P systems, if the attendance time of the fire service (whether local authority or private) does not exceed five minutes, Table 6 should be replaced by Table 7.

part one | guide to design of fire systems

detector coverage

Detector Type	Column 1 Generally applicable maximum ceiling height	Column 2 10% of ceiling height no greater than
Heat Detectors (BS EN 54-5):		
Class A1	9.0	10.5
Other Classes	7.5	10.5
Point Type Smoke and Carbon Monoxide Detectors		
	10.5	12.5
Optical Beam Smoke Detectors (BS 5839-5)		
	25.0	25.0
Aspirating Smoke Detector Systems complying with BFPSA code of practice for Category 1 aspirating detector systems:		
Normal Sensitivity	10.5	12.5
Enhanced Sensitivity	12.0	14.0
Very High Sensitivity	15.0	18.0
Other fire detectors		
As specified by manufacturer		

table 6. Ceiling height limits (general).

6.10 Walls and Partitions

A wall has two effects on the movement of smoke under a ceiling:

1. It slows down its movement towards the wall.
2. It deflects it in a direction parallel to the wall.

part one | guide to design of fire systems

detector coverage

Detector Type	Column 1 Generally applicable maximum ceiling height	Column 2 10% of ceiling height no greater than
Heat Detectors (BS EN 54-5):		
Class A1	13.5	15
Other Classes	12	15
Point Type Smoke and Carbon Monoxide Detectors		
	15	18
Optical Beam Smoke Detectors (BS 5839-5)		
	40	40
Aspirating Smoke Detector Systems complying with BFPSA code of practice for Category 1 aspirating detector systems:		
Normal Sensitivity	15	18
Enhanced Sensitivity	17	21
Very High Sensitivity	21	26
Other fire detectors		
As specified by manufacturer		

table 7. Ceiling height limits (category P systems and 5 minute fire service attendance).

Because of the slowing down effect, there tends to be dead spots near the wall. The code therefore states that detectors

should not be mounted within 500mm of any wall or partition. (Sections of the optical beam of an optical beam detector closer than 500mm to a wall or partition should be discounted from providing fire detection).

detector coverage

Detectors within rooms that open onto escape routes in a Category L3 system may be sited in the normal manner. However, as a special relaxation for these detectors only, the detectors may be sited on a wall, close to any door that opens onto an escape route. Wall mounted detectors should be sited such that the top of the detection element is between 150mm and 300mm below the ceiling, and the bottom of the detection element should be above the level of the door opening. However, in rooms with a high ceiling (e.g. exceeding 4m in height), a variation might need to be considered, so that the detector will operate before the door is under serious attack by fire.

6.11 Voids

Ceiling and under-floor voids 800mm or more in height should also be protected by detectors. (Occasionally, however, a variation, whereby detectors are omitted, might be considered in the case of voids in which the fire risk is low and the void is not a route for fire spread beyond the room of origin). Any void less than 800mm in height need not be protected unless extensive spread of fire or its products, particularly between rooms or compartments, can take place within it before detection or, on the basis

of a fire risk assessment, protection is considered to be warranted.

Where it is considered necessary to install detectors in shallow voids having poor ventilation, for example under-floor service voids, special care should be taken with the positioning of the detectors. As the initial smoke layer in a fire usually takes up the top 10% of the void height, in shallow voids this may be small compared with the dimensions of the detector. Care should therefore be taken to ensure that the sensing element of the detector lies within the top 10% of the void's height or the top 125mm, whichever is greater.

6.12 Perforated Ceilings

Detectors above a perforated false ceiling may be used for protection of the area below the false ceiling if:

- 1) The perforations are substantially uniform, appear across the complete ceiling and throughout they make up more than 40% of the surface; and
- 2) The minimum dimension of each perforation in any direction is 10mm; and

part one | guide to design of fire systems

detector coverage

- 3) The thickness of the ceiling is not greater than three times the minimum dimension of each perforation.

In all other cases, detectors should be mounted below the false ceiling, and if protection of the void above the false ceiling is necessary, further detectors should be installed on the true structural ceiling within the void.

6.13 Ventilation

Ventilation systems in buildings should also be taken into account when designing fire systems because air movements in a space can have a number of effects on the operation of the devices.

Extraction systems can draw the fire products away from normally sited detectors, and fresh air inlets can stop clean air passing over detectors even when the room air is smoky. Increased air turbulence can give increased dilution of the smoke, and, in the case of ionization smoke detectors, clean air can cause a false alarm if it is moving fast enough.

All heat and smoke detectors depend on the movement of fire products from the fire to the detector. Movement of air in the

building may be due to many causes, all of which can have an effect on the movement of the fire gases. As the fire gets bigger its convective effects gradually overpower all other causes of air movement. This, however, is not of much use to us as we need to detect fires when they are small.

Computer Suites are a case of special importance lies in the protection of computer suites. These usually combine a high financial value with high ventilation rates; just when we need to detect fires particularly quickly, the ventilation makes things especially difficult! BS 6266 (Code of practice for fire protection for electronic equipment installations) should be consulted here.

Ventilated Rooms the code provides useful advice on installation of detectors in ventilated rooms 22.3m. Detectors should not be mounted directly in the fresh air input from air conditioning systems. In general, a spacing of not less than 1m between the detector and the air inlet should be maintained. Where the air inlet is through a perforated ceiling, the ceiling should be non perforated for a radius of at least 600mm around each detector.

Smoke Detectors in Ventilation Ducts Sometimes, smoke detectors are installed within air extraction ducts. These detectors

detector coverage

cannot give adequate protection of the area from which air is extracted, as the extraction system may be shut down at certain times. However, they are sometimes installed as supplementary protection (e.g. to shut down recirculation of air). The detector may be mounted outside the duct, with a probe (see 5.2.7) extending into the duct itself. The smoke detectors or probes should be installed in straight stretches of ductwork, at a distance from the nearest bend, corner or junction, of at least three times the width of the duct. Only detectors deemed suitable for this application by the manufacturer should be used. Normally, a duct probe should cover the wider dimension of the duct, and the length of the probe should be at least two-thirds of that dimension.

6.14 Lantern-lights

A lantern-light or cupola can form a reservoir for smoke. If it is used for ventilation, it also forms a chimney, through which smoke will flow. BS 5839-1 recommends that if any lantern-light within a protected area is 800mm or more in depth, or is used for ventilation, a fire detector should be sited in the lantern-light.

part one | guide to design of fire systems

manual “break glass” call points

7. Manual “Break Glass” Call Points

7.1 General Information

All Category L1, L2, L3 and L4 systems must include call points, so that, in the event of a fire, people can raise the alarm immediately. In practice, usually Category L5, P1 and P2 systems also incorporate manual call points, unless these are provided in a separate system. Manual call points should conform to BS EN 54-11. ‘Type A’ call points, in which only a single action is necessary to raise the alarm (i.e. breaking the glass) should be used. However, subject to the agreement of the enforcing authority, a hinged, transparent cover may be used if the call points are likely to be subject to casual malicious operation. (See Section 8).

All call points in the installation must have the same method of operation unless there is a special reason for differentiation. A system in which some call points require impact by a hammer and others just require thumb pressure is not acceptable.

The delay between operation of a call point and the sounding of the alarm should not exceed three seconds.

Normal break glass call points might not be acceptable in food preparation areas or

areas where particularly explosive atmospheres are likely to be present. If installed in food preparation areas, breaking the frangible element may result in glass fragments getting into food.

7.2 Siting of Manual Call Points

The basic principle of manual call point siting is that no one should be able to leave a building, or a storey of a building, without passing a manual call point. BS 5839-1 recommends that manual call points should be located on escape routes and, in particular, at all storey exits and all exits to open air. Note that, in the case of exits to open air, these may, or may not actually be designated as fire exits.

In the case of manual call points located at storey exits, the code offers a choice of siting. The manual call points may either be located on the staircase landings or within the accommodation, adjacent to the door to the stairway. However, in a multi-storey building with phased evacuation, the two options for manual call point siting are not given by the code; in this case, manual call points should not be located on stairway landings. Where horizontally adjacent areas may be evacuated separately in a building with phased evacuation, the code recommends that additional ma-

part one | guide to design of fire systems

manual “break glass” call points

nual call points are provided to ensure that one manual call point is located at every designated exit from an alarm zone; unless this recommendation is satisfied, the appropriate areas might not be evacuated in the first phase.

The code sets a limit on the maximum distance that anyone should have to travel to reach the nearest manual call point. Generally, this figure is 45m, but the figure is reduced to 25m where processes in the area result in the likelihood of rapid fire development (e.g. as a result of the presence of highly flammable liquids or flammable gases) or where a significant proportion of occupants have limited mobility and it can reasonably be anticipated that one of these occupants will first operate the fire alarm system in the event of fire.

At the design stage of the system, it may be difficult to actually measure, on drawings, the maximum distance that anyone will have to travel to reach a manual call point. For example, the final fit-out or layout of partitions, equipment, etc may not be known. In this case, the code recommends that sufficient manual call points be provided to ensure that the maximum straight line distance between any point in a storey and the nearest manual call point does not exceed 30m (or 16m in situations

in which the maximum distance of travel to a manual call point is limited to 25m). Ultimately, on completion of a system, however, it is the actual distance of travel to a manual call point, measured along the route that a person would actually follow, that matters; at that stage, the straight line distance does not matter.

Once the above criteria are satisfied, for compliance with the code the designer will need to ensure that, where specific equipment or activities result in a high fire hazard, a manual call point is sited in close proximity. Examples of such areas given in the code are kitchens or cellulose paint spray areas. As it happens, in both these cases, further special requirements might apply to the manual call points. For example, the cellulose spraying area might require the use of equipment certified for use in potentially explosive atmospheres. Within kitchens, it is possible that call points with non-glass frangible elements are necessary, although, in practice, such call points are more usually limited to food processing factories and the like.

The code recommends that manual call points are fixed at a height of 1.4m above finished floor levels, at easily accessible, well illuminated and conspicuous positions free

part one | guide to design of fire systems

manual “break glass” call points

from potential obstruction. A ‘tolerance’ of 200mm in mounting height is permitted under the code without the need for it to be treated, or recorded, as a variation. The measurement should be made between the finished floor level and the centre point of the frangible element. Call points should be sited against a contrasting background to assist in easy recognition.

A mounting height lower than 1.4m is acceptable in circumstances where there is a high likelihood that the first person to raise an alarm of fire will be a wheelchair user.

Manual call points may be flush mounted in locations where they will be seen readily. However, where they will be viewed from the side, they should be surface mounted or only semi-recessed, such that the front face is proud of the mounting surface (e.g. the wall of a corridor) by at least 15mm.

part one | guide to design of fire systems

limitation of false and unwanted alarms

8. Limitation of False and Unwanted Alarms

8.1 Role of the Designer

Section 3 of BS 5839-1 is devoted to limitation of false alarms. In the code, the designer is considered to be the key player in the limitation of false alarms. It is a specific recommendation of the code that the system designer should ensure that the system design takes account of the guidance contained in Section 3 of the code. The certificate of compliance that the designer must complete not only certifies that the design complies with Section 2 of the code, it also certifies that account has been taken of the guidance in Section 3. More specifically, the design certificate contains various tick boxes that the designer must consider and tick as appropriate to indicate which of various specific actions have been taken within the design to ensure that false alarms are limited. A further informative annexe sets out in schematic form the thought processes involved in ensuring that system design is sufficiently immune to false alarms (See Figure 24).

The code considers the role of the installer in limiting false alarms as much less significant. The logic is that the role of the installer is simply to install the system in

accordance with the requirements of the designer. However, the code recommends that a special check is carried out as part of the commissioning process to ensure that there is no obvious potential for an unacceptable rate of false alarms. Within the model certificate of commissioning, the commissioning engineer is specifically required to record that, taking into account the guidance in Section 3 of the code, no obvious potential for an unacceptable rate of false alarms has been identified.

The code suggests that it should be confirmed, before design begins, that automatic fire detection will be of a value that outweighs the potential for false alarms. In general, of course, this will be the case, but, in the case of some simple small buildings in which all areas are occupied on a 24 hour basis, automatic detection may be of little benefit to fire safety. Other than in such rare cases, it will, of course, be inappropriate to avoid fire detection as the means of limiting false alarms.

However, the code does advocate that, at the design stage, the designer makes at least a qualitative judgement as to the likely frequency of false alarms. In the case of very large systems with many smoke detectors, it might even be appropriate for the designer to provide the user with gui-

part one | guide to design of fire systems

limitation of false and unwanted alarms

dance on the approximate rate at which false alarms could occur. This might then identify the need for incorporation of measures within the design to limit the number of false alarms; an example might be 'filtering measures', which are discussed later in this Section.

This quite onerous duty on the designer might, at first sight, appear somewhat theoretical, academic and idealistic. Certainly, it will hardly be appropriate for the designer of a fire alarm system for a small shop, which might comprise only two or three manual call points, half a dozen detectors and a few bells, to engage in dialogue with the user regarding the anticipated number of false alarms and special design measures for their avoidance! However, this guidance in the code is practical and sensible in the very large installations to which the guidance refers.

part one | guide to design of fire systems
limitation of false and unwanted alarms

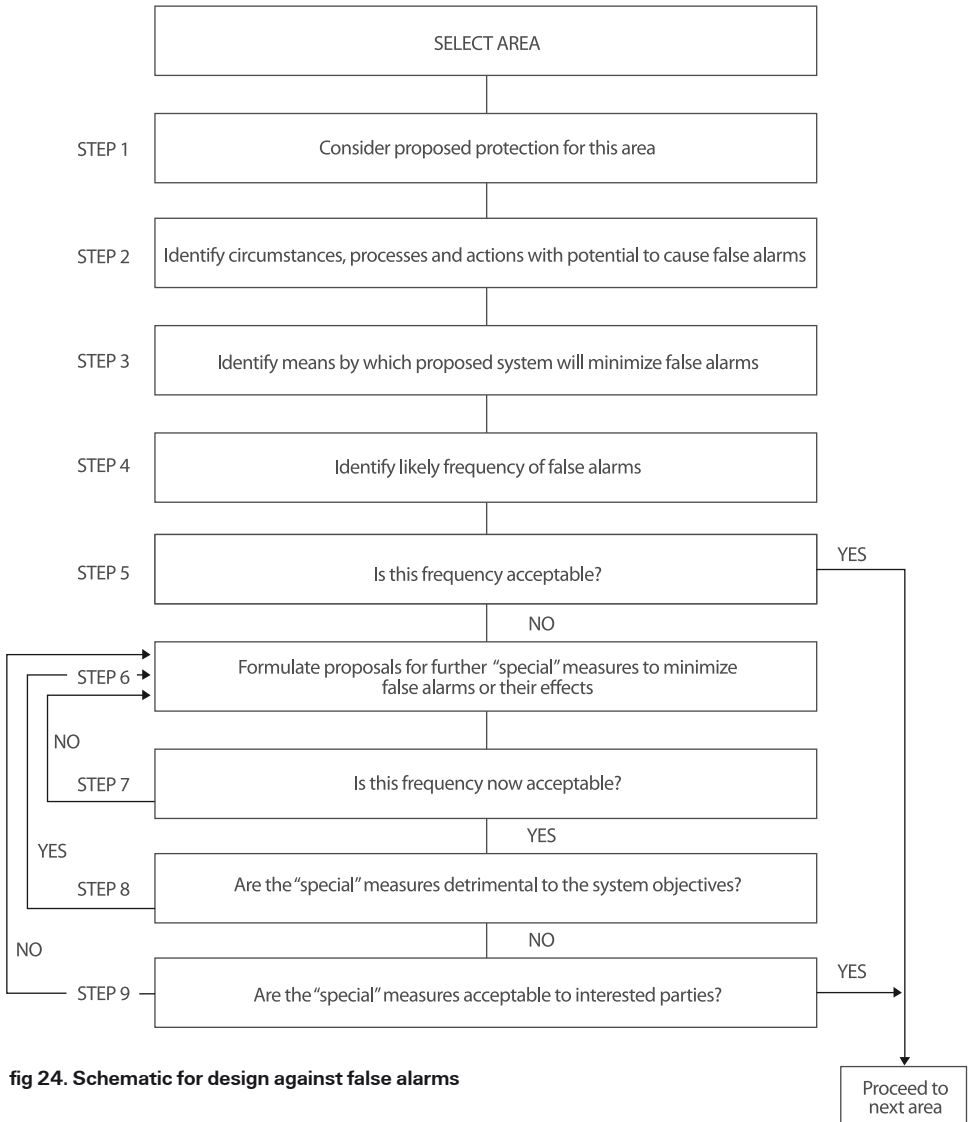

fig 24. Schematic for design against false alarms

part one | guide to design of fire systems

limitation of false and unwanted alarms

8.2 Categories of False Alarm

The code recognizes four different categories of false alarm, albeit that the generic term 'false alarm' is used in the code to describe any fire signal resulting from a cause(s) other than fire.

The four categories of false alarms are described and defined as follows:

Unwanted alarms, in which a system has responded, either as designed or as the technology may reasonably be expected to respond, to any of the following:

A fire-like phenomenon or environmental influence (e.g. smoke from a nearby bonfire, dust or insects, processes that produce smoke or flame, or environmental effects that can render certain types of detector unstable, such as rapid air flow);

Accidental damage; Inappropriate human action (e.g. operation of a system for test or maintenance purposes without prior warning to building occupants and/or an alarm receiving centre);

Equipment false alarms, in which the false alarm has resulted from a fault in the system;

Malicious false alarms, in which a person operates a manual call point or causes a fire detector to initiate a fire signal, whilst knowing that there is no fire;

False alarms with good intent, in which a person operates a manual call point or otherwise initiates a fire signal in the belief that there is a fire, when no fire actually exists.

8.3 Requirements for Service Technicians

The code recommends that, at the time of every service visit, the system false alarm record should be checked carefully. The code identifies three matters that should be brought to light by this check.

Firstly, the rate of false alarms during the previous twelve months, expressed as number of false alarms per 100 detectors per annum, should be determined by the service technician. Secondly, it should be determined whether, since the time of the

part one | guide to design of fire systems

limitation of false and unwanted alarms

previous service visit, two or more false alarms, other than false alarms with good intent, have arisen from any single manual call point or fire detector (or detector location). Thirdly, it should be determined whether any persistent cause of false alarms can be identified from a study of the false alarm log. As part of the service work, a preliminary investigation should be carried out if any one or more of four circumstances is found to apply, namely:

- 1) The rate of false alarms over the previous twelve months has exceeded one false alarm per 25 detectors per annum.
- 2) More than eleven false alarms have occurred since the time of the previous service visit (i.e. typically, within the previous six months).
- 3) Two or more false alarms (other than false alarms with good intent) have arisen from any single manual call point or fire detector (or detector location) since the time of the last service visit.
- 4) Any persistent cause of false alarms is identified.

8.4 False Alarm 'Rates'

The code advises that systems in which the parties responsible have not taken adequate care to limit false alarms, and systems that produce unacceptably high rates of false alarms, need to be regarded as non-compliant with the code. Such a non-compliance could bring with it civil liability and implications for insurance of the property, as well as possible enforcement action by enforcing authorities. Indeed, the code notes that, in the future, it is possible that a fire authority will take appropriate action if a fire alarm system consistently produces false alarms at unacceptable rates.

This, therefore, introduces the concept of an 'acceptable' rate of false alarms. The code is realistic enough to acknowledge that, while any false alarm is undesirable, it must be accepted that, particularly in installations that incorporate a large number of automatic fire detectors, complete elimination of false alarms is impossible. The best that can be expected is that the rate of false alarms from any installation falls within limits defined as 'acceptable'.

Factors that will affect the number of false alarms include the environment (including the electromagnetic environment), activities in the building, the level of occupation

part one | guide to design of fire systems

limitation of false and unwanted alarms

of the building and the standard of management in the building, the latter of which will affect matters such as control over third parties, (e.g. contractors), and the potential for malicious operation of manual call points.

However, the code suggests that a key factor will be the number of automatic fire detectors in the installation. Thus, the code advises that the number of false alarms that can be anticipated is virtually proportional to the number of automatic fire detectors installed.

This is because each detector can be considered as a potential generator of false alarms as a result of environmental factors and activities within the area of the detector, as well as, of course, the possibility of a detector fault. The code notes that the ratio of false alarms to number of detectors in the installation will depend on the extent to which smoke detectors are used; systems that are purely manual, or in which heat detectors are used, should not normally produce many false alarms.

As a guide, the code suggests that, in a relative benign environment, in which there is no tendency for dust, fumes or insects to occur, and in which there is a good standard of management, false alarm rates equal to,

or less than, one false alarm per 100 detectors per annum are possible. While this figure is not intended as a norm or 'average', it might, therefore, be regarded as an ideal target for false alarm management under ideal conditions. A more realistic expectation on industrial sites with shift working is suggested by the code to be one false alarm per 75 detectors per annum.

The code does not, however, suggest that the above figures are easily achievable. On the other hand, it does suggest that, in general, false alarm rates of one false alarm per 50 detectors per annum can be readily achievable with modern technology systems, unless there are severe environmental challenges for automatic fire detection. There is a tentative suggestion in the code that this rate might, therefore, be quite reasonable and 'acceptable' on an industrial site with processes that create an unfavourable environment for automatic fire detectors.

On the other hand, it is suggested that this rate might not be 'acceptable' in a controlled environment, such as a computer room.

These figures now provide the user with some form of target, however imprecise it might be, at which to aim in any initiative

part one | guide to design of fire systems

limitation of false and unwanted alarms

to reduce false alarms. However, the lack of precision in these figures, and the number of variables that will affect the actual false alarm rate in any specific installation, are such that it would not be reasonable to deem the rate of false alarms as unacceptable simply because these particular figures are not reached. Nevertheless, since the code introduces the concept of an 'unacceptable rate of false alarms', there must be some (much higher) rate of false alarms that does not simply fall short of the possible target ideal, but that is quite positively unacceptable.

The code defines such a level. The advice given is that, in general, in systems with more than 40 automatic fire detectors, a rate of more than one false alarm per 20 detectors per annum is never to be regarded as acceptable, particularly if the false alarms result in evacuation of the premises or summoning of the fire service. In premises with 40 automatic fire detectors or less, more than two false alarms per annum is to be regarded as unacceptable. It is these figures that are, therefore, used as the basis for the 'trigger' at which an in-depth investigation by suitable specialists should be carried out.

Specifically, the code recommends that, in systems that incorporate more than 40 au-

tomatic fire detectors, the user should instigate an in-depth investigation by suitable specialists if, in any rolling period of twelve months, either:

- 1) The average rate of false alarms exceeds one false alarm per 20 detectors per annum; or
- 2) If three or more false alarms are initiated by any single manual call point or automatic fire detector (or detector location).

In systems that incorporate 40 or less automatic fire detectors, the in-depth investigation should be instigated by the user if, in any rolling twelve month period, three or more false alarms occur.

In 2008 CFOA (Chief Fire Officers Association) introduced a new policy for the reduction of false alarms and unwanted fire signals. The aim of this policy was to reduce the number of false alarms generated by fire detection and alarm system, and to reduce the number of UWFS (Unwanted Fire Signals) sent to F&RS (Fire and Rescue Systems).

The CFOA policy calls for a considerably better performance from automatic fire detectors than required by the code,

part one | guide to design of fire systems

limitation of false and unwanted alarms

in respect of false alarms. It also recommends that the types of Call Filtering be adopted to help reduce false alarms calling the F&RS.

The policy also outlines methods of registering a fire detection alarm system together with possible reductions in F&RS attendance levels to repeat false alarm offenders. Full details on the policy can be found at www.cfoa.org.uk

8.5 Causes of False Alarms

The code lists 20 recognised causes of false alarms. These are as follows:

- Fumes from cooking processes (including toasting of bread);
- Steam (from bathrooms, shower rooms and industrial processes);
- Tobacco smoke;
- Dust (whether built up over a period of time or released from an industrial process);
- Insects;
- Aerosol spray (e.g. deodorants and cleaning fluids);
- High air velocities;
- Smoke from sources other than a fire in the building (e.g. from an external bonfire);
- Cutting, welding and similar “hot work”;
- Processes that produce smoke or flame (e.g. flambéing of food);
- Cosmetic smoke (e.g. in discotheques and theatres);
- Incense;
- Candles;
- Electromagnetic interference;
- High humidity;
- Water ingress;
- Substantial fluctuation in temperature;
- Accidental damage (particularly to manual call points);
- Testing or maintenance of the system, without appropriate disablement of the system or warning to building occupants and/or an alarm receiving centre;
- Pressure surges on water mains serving automatic sprinkler systems that are interfaced with the fire alarm system.

The code acknowledges that most of these causes can be minimized by appropriate choice of detection system and suitable management arrangements.

Equipment false alarms, associated with faults in equipment, can, on the other

part one | guide to design of fire systems

limitation of false and unwanted alarms

hand, be minimized by choice of good quality equipment that satisfies the appropriate product standards. Third party certification of the equipment provides a form of warranty of compliance. Once the equipment has been installed, regular servicing is important to ensure continuing satisfactory operation.

As noted in the code, the third category of false alarms, namely malicious false alarms, most commonly occur in certain public buildings, such as shopping centres, places of entertainment, certain public houses, public car parks and sports centres, and in educational establishments, such as universities and schools. These false alarms generally involve operation of manual call points.

The fourth category of false alarms, namely false alarms with good intent, is difficult to prevent and is, in any case, unlikely to present a significant problem. Moreover, it is generally undesirable to attempt to minimize false alarms with good intent, since the principles of fire safety dictate that it is entirely appropriate for people to raise the alarm, by operating a manual call point, if they suspect that there might be a fire. The code notes, therefore, that it is important that people are never discouraged from doing so.

8.6 Practical Measures to Limit False Alarms

One entire clause (clause 35) of Section 3 of the code is devoted purely to measures to limit false alarms. Clause 35 contains no less than 30 specific recommendations for consideration by the relevant parties. The measures advocated are divided into eight groups, namely:

- Siting and selection of manual call points.
- Selection and siting of automatic fire detectors.
- Selection of system type.
- Protection against electromagnetic interference.
- Performance monitoring of newly commissioned systems.
- Filtering measures.
- System management.
- Regular servicing and maintenance.

The 30 specific recommendations are not intended to constitute definitive 'rules'. On the other hand, they cannot be ignored if the various stages in system evolution and use are to comply with the code. Thus, the code recommends that the 30 recommendations in question be taken into account by any parties responsible for specification, design, commissioning or verification

part one | guide to design of fire systems

limitation of false and unwanted alarms

of a fire alarm system, and by maintenance organizations at the time of consideration of false alarm problems.

8.6.1 Siting and Selection of Manual Call Points

The recommendations for suitable siting and selection of manual call points relate primarily to avoidance of exposure of call points to accidental damage and malicious operation. Principally, this involves care in siting within certain high risk areas. As examples of areas in which there might be exposure to accidental damage, the code quotes areas in which trolleys or forklift trucks are used, and sports halls and gymnasia, in which ball sports are played. As examples of areas in which there is significant potential for malicious operation of call points, the code suggests shopping malls, some public houses, cinemas, theatres, nightclubs, schools, universities, certain public entertainment premises and public car parks.

In the case of shopping malls, the code recommends that manual call points should not be located within the malls themselves. In certain of the public premises described above, the code recommends that, subject to the agreement of all relevant enforcing authorities, it might be appropriate either

to omit manual call points from areas accessible to the public or to site them so that they are accessible only to authorized persons, provided there is adequate surveillance of the entire premises by people or CCTV and that manual call points are provided at suitably staffed locations. For example, it is not uncommon, in the case of certain public houses, to locate manual call points behind the bar.

Where mechanical damage is likely, the code refers to the use of guards. Hinged covers are also advocated for consideration as a form of guard and as a measure to limit malicious false alarms in the case of schools, universities, certain public entertainment premises and public car parks. Again, however, this would require the agreement of all relevant enforcing authorities, as the manual call points would not then conform to the requirements of BS EN 54-11[2] for Type A manual call points, and agreement of a variation from the normal recommendations of the code would be necessary. In the case of public car parks, the code suggests that consideration might also be given to the use of a suitable emergency voice communication system (e.g. emergency telephones or an intercom system) in lieu of manual call points. This would also require approval

part one | guide to design of fire systems

limitation of false and unwanted alarms

of enforcing authorities, and it would be appropriate for such a system to comply with BS 5839-9[3].

Ingress of moisture into a manual call point can cause malperformance of the device. In the case of an addressable system, such an event can cause various random fault and fire signals. Accordingly, the code recommends that, in areas in which manual call points are exposed to moisture, suitably moisture-resistant devices should be used. In practice, the performance would be specified by means of a relevant IP rating (e.g. IP X5). As examples of such areas, the code gives external locations, wet areas of industrial buildings, food-processing areas that are subject to periodic washing down and certain kitchens. A practical example would be the case of breweries, where there are often 'wet' areas. In many kitchens, ingress of water is not a recognized problem, but it is not unknown for condensation to create problems for manual call points, and water could, of course, occur in wash-up areas.

8.6.2 Selection and Siting of Automatic Fire Detectors

In the case of automatic fire detectors, the code refers to 'selection and siting', whereas, in the case of manual call points, the

term used was 'siting and selection'. This reversal of words is not accidental. In the case of manual call points, the code regards the siting of the devices as the critical factor, whereas, in the case of automatic fire detectors, greater emphasis is placed on selection.

However, as discussed above, if it is known that the provision of automatic fire detectors is likely to result in a high level of unwanted alarms, the first question that the designer should ask is whether, in fact, the provision of automatic fire detection is actually necessary. In this context, the 'necessity' will depend on the objectives of the fire alarm system, which should be clearly understood by the designer.

Over the last two decades, because of its greater sensitivity, smoke detection has become something of the 'default' form of fire detection, with heat detection specified only if it is obvious that smoke detectors would result in false alarms. However, the code recommends that, for systems complying with the 2002 version, consideration should be given to the use of heat detection, before smoke detection is specified. Thus, the code recommends that it should be confirmed that the use of heat detectors would not satisfy both the objectives of the fire

part one | guide to design of fire systems

limitation of false and unwanted alarms

alarm system and the recommendations of the code.

Unless there is an equipment fault, if heat detectors do generate false alarms, it is likely that the reason is either a high ambient temperature or rapidly fluctuating ambient temperatures. To avoid such false alarms, the code provides guidance on the 'headroom' that should exist between ambient temperatures and the temperature of operation of heat detectors. Rate of rise heat detectors should not be installed in locations in which rapid fluctuations in temperature may occur. Examples given in the code comprise kitchens, boiler rooms, loading bays with large doors to open air and lantern-lights.

A common perplexity to face designers is the type of smoke detector that should be specified (i.e. optical or ionization chamber). Clause 35 of the code provides guidance on considerations in respect of false alarms that should be taken into account in selecting point and optical beam smoke detectors.

part one | guide to design of fire systems

limitation of false and unwanted alarms

The information is presented in the form of a table, which indicates situations in which smoke detectors should never be installed and situations in which smoke detectors

should be avoided if possible. Further information is given on the type of smoke detector that should be avoided in a number of false alarm-prone situations.

Area	Smoke detectors should never be installed	Smoke detectors should be avoided if possible	If smoke detectors are installed they should not be of the type indicated
Kitchens	X		
Areas close to kitchens			Ionization chamber
Rooms in which toasters are used		X	Ionization chamber
Rooms in which people smoke		X (unless ventilation rates are such as to avoid the risk of unwanted alarms)	Optical
Bathroom and shower rooms	X		
Areas in which steam occurs under normal operations		X	Optical
Areas in which high concentrations of dust occur		X (regular cleaning or replacement of detectors may be necessary)	Optical
Areas in which large numbers of small insects (e.g. grain thrips) may enter			Optical (unless suitably designed to minimize unwanted alarms from insect ingress)
Areas in which the sensing element of the detector will be exposed to high air velocities			Ionization chamber
Areas in which there is high humidity		X	Ionization chamber
Areas in which vehicle or other engine exhaust fumes occur		X	Ionization chamber Optical beam
Areas in close proximity to openable windows		X	
Areas in which combustion gases may occur (e.g. certain boiler rooms)		X	

table 8. Considerations when using and selecting point and optical beam smoke detectors

part one | guide to design of fire systems

limitation of false and unwanted alarms

Most aspirating smoke detection systems are considerably more sensitive than normal point-type smoke detectors. Indeed, the high sensitivity of these devices is the most common reason for them to be specified (e.g. in critical electronic equipment rooms). However, the code advocates that special consideration is given to ensure that the high sensitivity does not result in unwanted alarms. In this connection, aspirating smoke detection is sometimes specified in circumstances in which its advantage is not so much its high sensitivity, but the opportunity to install relatively 'invisible' fire detection that will not affect the ambience of, say, a stately home.

In these circumstances, high sensitivity is not required in order to satisfy the objective of the system. Accordingly, in such cases, the code advocates the use of aspirating systems that can be arranged to provide sensitivity equivalent to that of point smoke detectors conforming to BS EN 54-7, since, were it not for the visual impact of point detectors, they might well have satisfied the fire safety objective quite adequately. This is possible with the VES-DA aspirating detection system.

Carbon monoxide fire detectors are sometimes specified in situations in which

smoke detectors or heat detectors could be used, simply to avoid the false alarms that might arise from smoke detectors, but to provide much more sensitive detection than could be afforded by heat detectors. However, it is important to take account of circumstances that might result in unwanted alarms from these detectors. Normally, such circumstances will be those in which carbon monoxide is generated, such as badly ventilated kitchens, areas in which vehicle or other exhaust fumes occur and some laboratories.

Similarly, it is a simple truism that infra-red and ultraviolet flame detectors should not be located in areas in which sources of infra-red or ultraviolet radiation create the potential for unwanted alarms. The mere presence of infra-red radiation itself, however, does not necessarily generate potential for unwanted alarms, as various techniques can be adopted to prevent this (e.g. generation of fire alarm signals from infra-red flame detectors only if the infra-red radiation sensed has the characteristic flicker frequency of a diffusion flame). Accordingly, the code recommends that the guidance of the manufacturer of the detector, in respect of sensitivity of detectors to other non-fire sources of radiation, should be taken into account.

8.6.3 Selection of System Type

Analogue fire detection systems are regarded as less prone to unwanted alarms than conventional fire detection systems. Even the simple pre-alarm warning incorporated within analogue systems provides an opportunity for the user to investigate a situation that, had it been permitted to continue, would have resulted in a false alarm.

The code recommends that, unless there are overriding considerations, systems that incorporate a high number of smoke detectors should be of the analogue type. It is for the designer to determine what constitutes a high number of smoke detectors, but a relatively tentative suggestion within the code is that a high number might be regarded as more than 100 detectors.

Arguably, the future for reduction of false alarms lies in the use of multi-sensor detection systems that incorporate measures to filter out false alarms from environmental influences that principally affect only one of the sensors incorporated within each detector. It should, however, be noted that not all multi-sensor detection systems incorporate such measures; some multi-sensor detectors use the multi-sensor

feature primarily to offer good sensitivity to a broader spectrum of fires.

However, the code recommends that, in systems that incorporate a very high number of automatic fire detectors (other than heat detectors), the use of systems that include multi-sensor fire detectors and incorporation of suitable measures to minimize the potential for unwanted alarms should be considered at the design stage. Again, only tentative advice on what constitutes a 'very high number' of detectors is offered in the code; more than 1,000 detectors is suggested as constituting a very high number. However, looking to the future, the code suggests that, as standards for multi-sensor fire detection systems are produced, and more proprietary systems become available, more definitive advice might be given and the definition of 'very high number' might be reduced, if evidence of significant improvements in unwanted alarm immunity can be established for these systems.

8.6.4 Protection Against Electromagnetic Interference

Modern fire alarm systems are less susceptible to electromagnetic interference than the systems of 10 - 20 years ago. Howe-

part one | guide to design of fire systems

limitation of false and unwanted alarms

ver, the code recognizes electromagnetic interference as a potential cause of unwanted alarms. Clause 28 of the code provides some practical guidance on avoiding false alarms as a result of electromagnetic interference. In addition, it is recommended that the designer should take into account the likely sources of electromagnetic radiation in the building. These include mobile telephones, two-way radios, mobile telephone base stations (which are often found now within buildings) and other high power transmitters.

In some cases, very high electromagnetic field strengths might occur. Examples are radio transmitter sites, airport terminals and radar stations. In these cases, the code recommends that guidance should be sought from the system manufacturer, so that special measures, such as the provision of filters on external circuits, can be incorporated to reduce the potential for unwanted alarms. In the case of an existing building, where unusually high field strengths occur, the code recommends that information be provided to the system manufacturer regarding the field strengths that exist. This, effectively, implies that actual measurements should be carried out in these cases.

8.6.5 Performance Monitoring of Newly Commissioned Systems

Sometimes, false alarms occur in the early life of a system. This can arise from 'infant mortality' of components, poor siting of detectors that was not identified before handover, and environmental influences that were not appreciated prior to handover. These early problems are sometimes attributed to 'settling in' of the system, but are really more accurately the result of previously undetected problems. In order to prevent these problems causing actual false alarms, the code recommends that, in the case of systems incorporating more than 50 automatic fire detectors, a 'soak period' should follow commissioning. A soak period is defined in the code as a period after a fire alarm system has been commissioned, but prior to handover, during which the system's performance in relation to false alarms and faults is monitored. Thus, other than in the case of small systems, handover, as envisaged in the code, is not complete until completion of the soak period.

The code recommends that the duration of the soak period should be at least one week, but the actual period should be defined by the designer and incorporated within any tender specification. Within

part one | guide to design of fire systems

limitation of false and unwanted alarms

the model design certificate, the designer is required to indicate whether no soak test is required, based on the number of automatic fire detectors, or to define the period for the soak test. Where a soak test is required, since it will immediately follow commissioning, the model certificate of commissioning also contains a space in which the period of any required soak test should be recorded.

Obviously, until successful completion of the soak test, the system should not be regarded as the means of giving warning of fire in the building. Thus, during this period, each manual call point should bear an indication that it is not to be used. In practice, this means that, in the programme for a new building project, allowance would have to be made for the soak period before occupation of a building. Where an existing fire alarm system is being replaced by a new system, strip out of the old system clearly should not begin until the completion of the new system's soak test. Practical difficulties may, however, arise in complying with the code if the new system uses the wiring of the old system. The code defines the criteria for successful completion of the soak test, namely that:

- 1) During the soak period, no false alarm occurred; or
- 2) Investigation of all false alarms that occurred, by the supplier of the system, has identified the cause of every false alarm and enabled any relevant measures to be taken to minimize potential for similar false alarms to occur in the future.

8.6.6 Filtering Measures

Even if all the above recommendations for limitation of false alarms are dutifully followed, the code acknowledges that the rate of false alarms (e.g. expressed as one false alarm per n detectors per annum), or the sheer number of false alarms, might be unacceptable. The code envisages that the unacceptable extent of false and unwanted alarms might actually be anticipated at the design stage or that it might only come to light after operational experience. For example, if there is a large number of automatic fire detectors, the number of false alarms that might be anticipated by the designer, even at the initial design stage, might be regarded by the user as unacceptable, even though the actual rate is well within the definition of acceptability given in the code.

Under these circumstances, the code suggests that 'filtering' measures might be appropriate, particularly in installations

part one | guide to design of fire systems

limitation of false and unwanted alarms

with a very large number of automatic fire detectors, which the code suggests might be, for example, more than 1,000 detectors. Two forms of 'filtering' are described in the code.

The first (and, in practice, the less common) form of filtering is the use of a 'time related system'. In such a system the form of protection varies on a time related basis. For example, smoke detectors may be disabled automatically during normal working hours, so that, in effect, the system is Category M during working hours and Category P outside normal working hours. This technique could not, of course, be applied if the function of the automatic fire detection were life safety, as it would, obviously, be needed when people were present.

Other forms of time related system include those in which detector sensitivity is reduced at certain times, such as during working hours, and multi-sensor systems in which one of the sensors is disabled (or reduced in sensitivity) at certain times. In the latter case, if, say, smoke sensors are disabled during normal working hours, but protection at these times by heat detectors is still required, the detector spacing should follow that recommended for heat detectors, rather than that recommended for smoke detectors.

In all of the above examples, the actual causes of false and unwanted alarms are not eliminated or reduced; it is merely that the false alarms are 'filtered out' by preventing response to the causes of false and unwanted alarms at certain times of day. It goes without saying, however, that the modified form of response, and associated reduction in the level of protection, needs to be understood by, and be acceptable to, the relevant interested parties.

The second form of filtering involves the use of a 'staff alarm'. The code defines a staff alarm as a restricted alarm, following the operation of a manual call point or automatic fire detector, given to certain staff in the premises to permit investigation prior to evacuation.

Secondly, although the definition refers to a delay in evacuation, quite often the summoning of the fire service (whether via the public emergency call system or via an alarm receiving centre) is also delayed, so that summoning of the fire service does not occur unless and until an evacuation is initiated. It might actually be preferable to delay the summoning of the fire service until the expiry of the investigation period if the fire brigade attendance time is less than the investigation period; otherwise, in these circumstances, at the time of arrival of the

part one | guide to design of fire systems

limitation of false and unwanted alarms

fire service, investigation is still underway, the premises are still fully occupied and no audible fire alarm signal is sounding. The arrival of the fire service under these circumstances may not only be unwarranted, but it may cause confusion.

Staff alarms are becoming quite common in large, complex buildings that are protected by a high number of automatic fire detectors, particularly smoke detectors. The use of a staff alarm does, however, necessitate a good standard of management. There must be sufficient staff to investigate, and manage the situation thereafter, at all times that the staff alarm arrangement applies, and there must never be any suggestion that staff might simply endeavour to cancel the alarm during the investigate period and then investigate at leisure.

In practice, the staff alarm normally applies at all times, but there is no reason why, in certain premises, it should not only apply at certain times of the day, such as normal working hours, in which case the system is also a time-related system.

Although filtering should, arguably, always be considered at the design stage in systems with very large numbers of smoke detectors, filtering measures should not be regarded as an 'easy' option to mask

shortcomings in system design that could be improved by other means. The code recommends that filtering measures should only be adopted under the following circumstances:

- 1) After consultation and agreement with all relevant enforcing authorities; and
- 2) In the case of Category P systems in which it is proposed to incorporate an investigation period prior to the summoning of the fire service, after consultation with the insurers; and
- 3) Where it is considered that either the rate of false and unwanted alarms (expressed as number of false alarms per 100 detectors per annum) or the actual number of false alarms, cannot be limited to a level acceptable to the user and the fire service by other means; and
- 4) Where it is considered that the incorporation of filtering measures does not negate the objectives of the system in terms of protection of life, property, business continuity or the environment.

part one | guide to design of fire systems

limitation of false and unwanted alarms

Point 4) above cannot be stressed strongly enough. The natural concern on the part of users to avoid the effects of false and unwanted alarms sometimes blinds them to the need for a strategy that will be robust in ensuring the safety of people in the event of an actual fire. A good false alarm strategy is not necessarily a good fire safety strategy!

Even so, properly designed filtering measures do incorporate safeguards to ensure that potential delays in implementing fire procedures in the event of fire are minimized. For example, the code recommends that filtering should not be applied to signals initiated by manual call points. Thus, during the investigation period, if anyone in the building, including those investigating the alarm signal, discover a fire, the alarm can be raised quickly by use of any nearby manual call point. (A staff alarm is sometimes accepted as the response to operation of a manual call point in public entertainment premises, but this is not primarily for the purpose of filtering out false alarms, but to enable pre-determined staff actions to be put in place to assist the public with evacuation.) Staff alarms should only be used where staff, including any night staff, are sufficient in number and fully trained in the action they are to take in the event of fire.

A further common safeguard incorporated within staff alarm arrangements is coincidence detection. When this arrangement applies, although only a staff alarm results from the operation of a single automatic fire detector, operation of any two detectors will result in a full fire alarm condition. The value of coincidence detection is acknowledged in the code, albeit that it is not specifically recommended that it should always be incorporated within a staff alarm arrangement.

If the fire service is not summoned immediately at the start of any investigation period associated with a staff alarm, it is essential that they are summoned immediately on expiry of this period. A note in the code acknowledges that reliability and compliance with this recommendation can be aided by the use of facilities to transmit signals automatically to an alarm receiving centre on expiry of the investigation period. Some fire authorities actually make this a requirement for acceptance of a staff alarm arrangement.

Filtering of alarm signals at the alarm receiving centre, in the form of a telephone call to the protected premises to verify that the alarm is genuine, is commonly used in respect of intruder alarm signals. It is uncommon for this

part one | guide to design of fire systems

limitation of false and unwanted alarms

to apply to fire alarm signals, but such an arrangement is not precluded. Care would, however, be necessary to ensure that filtering did not occur at the protected premises and also, subsequently, at the alarm receiving centre, as this would be likely to cause an unacceptable delay in transmission of signals to the fire service.

Automatic sprinkler systems are not prone to false alarms. False alarms as a result of actual water discharge from sprinkler heads is extremely rare, and, when it does occur, it is normally the result of significant events, such as mechanical damage (e.g. by forklift trucks), corrosion of heads in aggressive environments, freezing of unheated pipework, etc. However, unwanted alarms do sometimes occur in systems that are supplied from water mains, as opposed to the now more common form of supply, namely a water storage tank and pumps. In systems supplied directly from town mains, the pressure in the main may rise at night as a result of low demand. This increase in pressure can lift the clack of the alarm valve, permitting water to flow through the pipework that serves the hydraulic alarm gong. The normal means of providing a signal from a sprinkler system to a fire alarm system comprises a pressure switch within this pipework. Ac-

ordingly, a false alarm can arise under these circumstances.

Where a signal from an automatic sprinkler system that is supplied from water mains is used as an input to the fire alarm system, there should be liaison with the organization responsible for installing or maintaining the sprinkler system to minimize potential for unwanted alarms as a result of water pressure surges. In practice, this is usually achieved by a hydraulic or electronic time delay facility, and consideration of these measures is recommended by the code under such circumstances. An electronic time delay, which is probably more common, is usually achieved by use of a pressure switch that incorporates a variable time delay (for which the pressure sensed must exist) within the switch; a similar arrangement could be applied at the fire alarm control equipment, but it is normally at the sprinkler installation that the matter is addressed.

8.6.7 System Management

The code also makes recommendations for ongoing management of the fire alarm system by the user. As the user is unlikely to possess, or read, the code, it is important that the designer and supplier of the system inform the user regarding these

part one | guide to design of fire systems

limitation of false and unwanted alarms

recommendations. The recommendations in question are intended to ensure that, for example, contractors are properly appraised of the measures necessary to minimize false and unwanted alarms during building work; various measures that are appropriate during such work are recommended in the code. The code also highlights the importance of ensuring that staff in the building are aware of the presence of automatic fire detection, so that they can avoid actions that could cause false and unwanted alarms. Staff also need to be informed when routine testing or maintenance work might cause the occurrence of a fire alarm signal. More generally, the building, and any plant in the building, should be adequately maintained to ensure that leaking roofs, steam leaks, etc do not cause unwanted alarms.

When false and unwanted alarms do occur, the code recommends that suitable action should be taken by the user. Relevant actions are discussed in the code, but it should be stressed that, at the very least, this should comprise recording of the false and unwanted alarm and all relevant associated information in the system log book.

8.6.8 Servicing and Maintenance

In order to limit false and unwanted alarms, servicing and maintenance of the system should be carried out by a competent organization. Generally, a contract for periodic servicing and emergency call out should be set up before the system becomes operational.

9. Means of Giving Warning to Occupants

Category M and Category L systems must be capable of giving an audible warning of fire throughout the building, as the principal purpose of these systems is to warn occupants in the event of fire, so that they can evacuate the building. In theory, a Category P system does not have to provide an audible warning throughout the building, since its purpose is purely to ensure that fire-fighting action is taken, and this might not necessitate an audible warning to all occupants of the building. In practice, a Category P system is usually combined with a Category M system, in which case the recommendations for audible alarm signals applicable to a Category M system will take precedence and be more onerous.

Strictly, nevertheless, the code only recommends that, in the case of a Category P system, the recommendations regarding audible alarm signals need only be applied in areas where such audible alarm signals are required. Thus, for example, in a building with an existing Category M system, a separate, supplementary Category P system could meet the recommendations of the code without a facility to provide an audible

warning throughout the building when detectors operate.

When designing fire alarm systems, careful consideration must be given to the positioning of sounders. The audibility of sounders can differ quite significantly depending upon where they are located. It should be ensured that sufficient, suitably located sounders are provided to ensure adequate audibility in all relevant areas of the premises.

9.1 Sound Pressure Level

The code recommends that, generally, the minimum sound pressure level produced by sounders in all accessible areas of the building should be at least 65dB(A) or 5dB above any other noise likely to persist for longer than 30 seconds, whichever is the greater [16.2.1]. There are, however, a number of relaxations from this recommendation, and these are set out below:

- The minimum figure of 65dB(A) is reduced to 60dB(A) in:
 - stairways;
 - enclosures of no more than approximately 60m² in area (e.g. cellular offices);

part one | guide to design of fire systems

means of giving warning to occupants

- specific points of limited extent. (This means that, although the designer should endeavour to achieve the minimum sound pressure level of 65dB(A), the system is still acceptable if, at one or more points of limited extent, the sound pressure level measured is between 60dB(A) and 65dB(A)).
- No minimum sound pressure level applies to habitable enclosures of less than 1m² in area.
- No measurement of sound pressure level need be carried out within 500mm of any walls or partitions, other than within rooms in which the fire alarm system is intended to rouse people from sleep.
- If any area is specifically designated as that from which the fire service will be summoned in the event of fire (e.g. a telephone operator's room), the code does not specify a minimum sound pressure level, but it needs to be ensured that the fire alarm signal is not so loud as to interfere with telephone speech. If, however, the sound pressure level of background noise in this area is greater than 60dB(A), the sound pressure level of the fire alarm

signal should be 5dB above the sound pressure level of the back ground noise. (Care should also be taken to ensure that sounder frequencies can not confuse tone dialling systems, leading to failure of the emergency call).

If the fire alarm system is intended to rouse people from sleep, the code recommends that the sound pressure level at the bed-head, within rooms in which people sleep, should be at least 75dB(A). In practice, this will necessitate the provision of a fire alarm sounder within each room in question.

part one | guide to design of fire systems
 means of giving warning to occupants

Table 9 below shows the typical sound pressure level produced by various types of sounder at different distances. It should be noted that, in the case of electronic sounders, the figures quoted relate to sound pressure level measured along the axis of the sounder. Electronic sounders are directional in output, and a lower sound pressure level will be achieved at points off the axis of the sounder. In such cases, the manufacturer's data sheet should be consulted.

SOUNDER TYPE	SOUNDER PRESSURE LEVEL dB (A)				
	@ 1 Metre	@ 2 Metre	@ 4 Metre	@ 8 Metre	@ 12 Metre
6" Bell	91	85	79	73	67
8" Bell	95	89	83	77	71
Banshee Sounder	103	97	91	85	79
Bedlam Sounder	113	107	101	95	89
Bedhead Sounder	96	90	84	78	72
Squashni Sounder	85	79	73	67	-

table 9. Sound pressure level at various distances

part one | guide to design of fire systems

means of giving warning to occupants

9.2 Discrimination and Frequency

Two important factors relating to any sounders used in fire alarm systems are Discrimination and Frequency.

Discrimination The type, number and location of fire alarm sounders should be such that the alarm sound is distinct from all the background noise. The note of the fire alarm sounders should also be distinct from any other alarm sounds that are likely to be heard.

All fire alarm sounders within the building should have similar sound characteristics, unless particular conditions, such as an area of high background noise make this impracticable. In this case, other types of fire alarm device may also be used, such as flashing coloured beacons [17.2].

Frequency Young persons are most sensitive to sounds at frequencies between 500 Hz and 8,000Hz. Age and hearing damage reduce the sensitivity of the ear, particularly to frequencies above 2,000 Hz. Partitions, dividing walls and doors attenuate sound; in general, the higher the frequency of the sound, the greater the attenuation.

Because of this, fire alarm sounders should therefore ideally lie in the range 500 Hz to 1,000 Hz [16.2.1b)]. However, if the frequency of background noise is within this frequency range, and the level of background noise is such that the sound of fire alarm sounders producing 500 - 1,000Hz could be 'masked' by the background noise, the use of fire alarm sounder frequencies outside this range is acceptable.

9.3 Sound Continuity

The code states that the sound of the fire alarm should be continuous, although the frequency and amplitude may vary (for example, as in a warbling note) to indicate the need for evacuation or other urgent response.

9.4 Audible Alarms in Noisy Areas

In areas of a building where there are noisy machines, the power requirements of high powered sounders needed to comply with the recommendations of the code (see 9.1 above) may place excessively high demands on the power capacity of the fire alarm system. In such cases, the primary sounders may be reinforced by secondary sounders operated directly from the mains

part one | guide to design of fire systems

means of giving warning to occupants

supply and without standby supplies, provided the following conditions apply [16.2.1e]:

1. The mains powered sounders are operated from the same final circuit(s) as the noisy machines, so that failure of the supply to these secondary sounders also results in the silencing of the noisy machines.
2. When the machine noise ceases and the secondary sounders are out of service, the primary sounders meet the sound levels recommended in the code (see 9.1 above).

In premises designed for public entertainment, retail and similar premises, in which the sound pressure level of music is likely to be greater than 80dB(A), the music should be muted automatically when a fire alarm signal is given. (If the sound pressure level of the music is likely to be between 60dB(A) and 80dB(A), the sound pressure level of the fire alarm signal should, of course, still be 5dB above the level of the music.

9.5 Alarm Zones

In many buildings, the fire alarm system is so arranged that, when any manual call point or fire detector operates, fire alarm sounders operate throughout the building, so that the entire building is evacuated simultaneously.

In larger, more complex buildings, it may be the case that, in the event of an alarm signal in one area, occupants in other areas are given only an 'alert' signal to warn them of the possible need for evacuation at a later stage. This occurs in buildings with phased evacuation, which is often used in tall buildings; in such cases, usually only two or more floors are evacuated at any one time.

In these cases, the premises are divided into 'alarm zones'. An evacuation signal can then be given in one alarm zone without giving an evacuation signal in other alarm zones; normally an 'alert' signal is given in these other alarm zones. Such an arrangement should only be used with the agreement of the building control and fire authorities. Care needs to be taken that overlap of signals between alarm zones does not result in confusion of occupants. It should be ensured that no occupant can clearly hear both an 'evacuate' signal and an 'alert' signal.

part one | guide to design of fire systems

means of giving warning to occupants

Where there is more than one alarm zone in the building, a separate evacuation control should be provided for each part of the premises in which an evacuation signal needs to be given simultaneously. However, in buildings with phased evacuation, sometimes there is inadequate staircase capacity to evacuate the entire building simultaneously. In the latter case, no single control that will result in an evacuation signal throughout all alarm zones simultaneously should be provided; such a control should, however, be provided in all other buildings with two or more alarm zones.

In a building with two or more separate alarm zones, 'alert' signals may stop automatically after 30 seconds, provided that, at periods not exceeding three minutes, the signal is restored for a period of at least ten seconds until it is manually silenced. While provision of this automatic silencing is not mandatory for compliance with BS 5839-1, the arrangement prevents unnecessary disruption of occupants until they are required to evacuate.

9.6 External Fire Alarm Devices

There is no need to provide external fire alarm sounders in order to comply with BS 5839-1. However, if the fire service consider that there would be a need for,

or benefit from, external alarm devices to direct them to the appropriate building or appropriate entrance to a building, such sounders may be provided. However, the code recommends that any such external fire alarm sounders in Category L and Category P systems should silence automatically after 30 minutes, unless the premises are continuously occupied, so enabling manual silencing by occupants at any time.

External indication may, instead, be given by a visual alarm device, such as a flashing beacon. In this case, the visual device can continue until appropriate manual action is taken (e.g. silencing sounders and/or resetting the system).

9.7 Voice Alarm Systems and Voice Sounders

Instead of using fire alarm sounders, audible alarms may comprise voice messages generated by a voice alarm system. A voice alarm system is a specially designed sound distribution system (i.e. public address system), which, in the event of fire, broadcasts an alarm warning tone followed by a voice message. Voice alarm systems are commonly used instead of conventional fire alarm sounders in premises occupied by a large number of mem-

part one | guide to design of fire systems

means of giving warning to occupants

bers of the public (e.g. shopping centre, transport terminal, large places of public entertainment, etc) and in buildings with phased evacuation. Voice alarm systems should comply with BS 5839-8.

In buildings in which it is not considered that a full voice alarm system is necessary, voice sounders can be used as an enhancement over conventional fire alarm sounders. Voice sounders are fire alarm sounders, connected to conventional fire alarm circuits, that generate and broadcast digitally recorded speech messages. Whereas, in a voice alarm system, there is normally a facility to override pre-recorded messages and transmit 'live' speech, this is not possible in a system that uses voice sounders. Guidance on the use of voice sounders is given in Annex E of BS 5839-8.

9.8 Fire Alarm Warnings for Deaf People

There is a need to warn deaf people in the event of fire, in which case additional facilities shall be provided. Where deaf people sleep in the building, vibrating devices, wired into fire alarm device circuits, can be placed under pillows or mattresses. Where deaf people have a need to move around a building, vibrating pagers can be given to each deaf person. Flashing beacons can

also be used as one of the facilities to warn deaf people.

Systems using vibrating pagers must be specially designed to satisfy the recommendations of BS 5839-1. This includes the provision of monitoring facilities, standby power supplies, etc, as recommended by BS 5839-1.

part one | guide to design of fire systems

control and indicating equipment

10. Control and Indicating Equipment

The control and indicating equipment used in all fire detection and alarm systems should comply with BS EN 54-2 : 1988. Confidence of compliance can be obtained by the use of equipment that is approved by the Loss Prevention Certification Board. Vds or other European accredited EN54 product test house.

Although we describe the features and operation of different types of fire detection and alarm systems in section 4, there are also other factors which should also be considered when designing a system, namely Siting of Control and Indicating Equipment, Location of Origin of the Alarm and Security of Control Equipment. Each of these topics is described below.

10.1 Siting of Control and Indicating Equipment

The siting of the control and indicating equipment should satisfy a number of recommendations:

1. Since the control equipment is essential for the operation of the system, it should be placed in an area of low fire hazard [23.2.1e)]. In a complex building with multiple entrances, it may be necessary to provide repeat indicator panel(s) at the building entry point(s) to be used by the fire brigade.
2. Indicating equipment, in conjunction with suitable manual controls should be sited at an appropriate location for both staff and fire-fighters responding to a fire signal. This should normally be an area on the ground floor close to the entrance of the building likely to be used by the fire service, or a suitably sited, continuously manned control room.
3. The ambient light level in the vicinity of all control and indicating equipment should be such that individual indications can be clearly seen, controls easily operated and any instructions or legends easily read.
4. In Category L and Category P systems, the area in which the equipment is sited should be protected by automatic fire detection. However, this recommendation does not apply if:

part one | guide to design of fire systems

control and indicating equipment

(I) The fire hazard level in the area in which the equipment is sited is negligible and there is an adequate degree of fire separation between this area and any area in which the fire hazard is not negligible; or

(II) The area in which the equipment is sited is continuously manned in the case of Category P systems, or continuously manned when the building is occupied by any person in the case of Category L systems.

5. Noise or other sound levels in the vicinity of the control equipment should not dilute the audible alarm given by the control equipment [23.2.1 d)].
6. In multi-occupancy buildings with communal areas, control and indicating equipment should be sited within a communal area. Otherwise, it should be sited in an area to which access is possible at all times when the building is generally occupied.

10.2 Location of Origin of the Fire

Although addressable systems can precisely locate the position of the fire, all fire detection and alarm systems (whether conventional or addressable) should provide zonal indicators (e.g. a matrix of LEDs or illuminated mimic diagram) to show the detection zone(s) from which there are alarm signals. This provides the fire brigade with a simple overview of all detection zone(s) in which fire has been detected, without the need to scroll through a display.

If the zone indicators simply provide an indication of detection zone number, there will be a need for a plan of the building, adjacent to the indicating equipment, to show diagrammatically the locations of all detection zones.

However, if the zone indicators take the form of an illuminated mimic (an example of which is shown in Figure 25), this combines the function of zonal indication and geographic representation of the detection zone(s) from which alarm signals are being given.

part one | guide to design of fire systems control and indicating equipment

10.3 Security of Control Equipment

The code recommends that the operation of certain controls be limited to authorised personnel only. Where the restriction is not provided on the control equipment, for example by means of a key switch, the code allows for security of the equipment to be provided by restricting access to it.

10.4 Networked Control Panels

In a large building, it is possible to network a number of control panels together, to form a 'networked system'. Generally, the network cables may need to be fire resisting and monitored, as they may form part of the critical signal path.

part one | guide to design of fire systems

power supplies

11. Power Supplies

Virtually all systems will be powered from the public mains supply, with a secondary standby supply being provided by rechargeable batteries (sometimes in conjunction with a standby generator). If the standby batteries are supplemented by an automatically started generator, it is permissible to reduce the standby battery capacity of Category M and L systems [25.4e].

Both the primary mains supply and the secondary standby supply must be able to provide the maximum load independently of each other. The alarm load of the fire alarm system is the maximum load which the power supply must provide under fire conditions. This includes power drawn during simultaneous operation of the control and indicating equipment, all sounders, all detectors, all manual call points and transmission of signals to an alarm receiving centre.

11.1 Mains Supply

Connection of all systems to the public mains supply should be in accordance with the recommendations outlined in BS 7671 (Requirements for Electrical Installations – IEE Wiring Regulations, Seventeenth Edition). The mains supply for the

system should be connected via an isolating switch–fuse or circuit breaker used solely for the purpose of the fire detection and alarm equipment. Any switch (other than the main isolator for the building) that disconnects the mains supply to the fire alarm system should be clearly labelled ‘FIRE ALARM: DO NOT SWITCH OFF’. Any protective device (such as a fuse) that serves only the fire alarm circuit should be labelled ‘FIRE ALARM’.

The supply to the fire alarm system should be supplied from the load (‘dead’) side of the main isolating device for the building. Since this isolates all supplies in the building, it does not need to be labelled with a warning that it isolates the supply to the fire alarm system.

The circuits supplying the fire alarm system should not be protected by residual current devices, unless this is necessary to comply with BS 7671. When a residual current device is necessary for electrical safety, a fault on any other circuit or equipment in the building should not be capable of resulting in isolation of the supply to the fire alarm system; the RCD for the fire alarm system should be independent.

part one | guide to design of fire systems

power supplies

To facilitate local isolation during maintenance, a double pole switch should be provided in the vicinity of the control and indicating equipment (and any other mains supply equipment forming part of the fire alarm system) so that maintenance technicians can isolate the mains supply to the fire alarm system locally to the equipment that the mains supply serves. The switch should be lockable to prevent unauthorised operation.

The presence of the normal or the standby supply should be indicated by a green indicator at the main control and indicating equipment, to show that power is being supplied to the system (whether from the mains supply or the standby supply).

11.2 Standby Supply

The standby supply should be provided by secondary batteries with an automatic charger. The batteries should have an expected life of at least four years; the code specifically disallows the use of car-starting type batteries. In order that the full life of the batteries is achieved, it is important to ensure that the characteristics of the charger match those of the batteries being used. The charger should be capable of charging fully discharged batteries in 24 hours.

In the event of a mains supply failure, the capacity of the standby supply must be likely to provide protection until the normal mains supply has been restored. The minimum requirements for the different system types and conditions are described in the following subsections.

11.2.1 Life Protection (Category M and L Systems)

The capacity of the standby batteries should be sufficient to operate the system for 24 hours normal operation, and also have sufficient capacity remaining at the end of this period to provide an evacuation signal throughout the building for 30 minutes.

If the building is provided with an automatically started standby generator that serves the fire alarm system (usually in conjunction with other essential supplies in the building), the capacity of the standby batteries should be sufficient to maintain the system in operation for at least six hours, after which sufficient capacity should remain to provide an 'evacuate' signal in all alarm zones for at least 30 minutes.

part one | guide to design of fire systems

power supplies

11.2.2 Property Protection (Category P Systems)

The capacity of the standby batteries required for property protection systems is dependent on whether or not a mains supply failure will be immediately recognised within the building or via a remote link to an alarm receiving centre.

The capacity of the standby batteries required for property protection systems is identical to that required for Category M and Category L systems (i.e. sufficient to operate the system for 24 hours and provide an evacuation signal for 30 minutes thereafter) PROVIDED:

1. The building is continuously manned, so that staff in the building would be aware of a power supply fault indication on the system within no more than six hours of its occurrence; or
2. The building is inspected outside normal working hours such that staff would be aware of a power supply fault indication within no more than six hours of its occurrence; or
3. Power supply fault signals are transmitted automatically to an alarm

receiving centre, instructed to notify a keyholder immediately on receipt of a fault indication from the premises.

In all other circumstances, the battery capacity should be sufficient to maintain the system in operation for at least 24 hours longer than the maximum period for which the premises are likely to be unoccupied, or for 72 hours in total, whichever is less, after which sufficient capacity should remain to operate all fire alarm devices for at least 30 minutes. If the building is likely to be unoccupied for more than the duration of the standby battery capacity at any time, and there is a facility for transmission of fire signals to an alarm receiving centre (as there normally will be in a Category P system - see Section 13), power supply fault signals should also be automatically transmitted to the alarm receiving centre, for immediate notification of a key holder. It should be noted that, in the case of Category P systems, there is no relaxation in standby battery capacity if an automatically started standby generator is provided.

11.2.3 Calculation of Standby Battery Capacity

For systems designed in accordance with BS 5839-1, compliance with the code requires that the battery capacity of val-

part one | guide to design of fire systems

power supplies

ve regulated lead acid batteries should be calculated in accordance with the following formula:

The formula in question is:

$$C_{\text{MIN}} = 1.25 (T_1 I_1 + D I_2 / 2)$$

where:

C_{MIN} = minimum capacity of the battery when new at the 20 hour discharge rate and at 20°C (in ampere-hours).

T_1 = total battery standby period in hours.

I_1 = total battery standby load in amperes.

I_2 = total battery alarm load in amperes.

D = a de-rating factor.

1.25 is a factor to allow for battery ageing.

The de-rating factor is intended to take into account the fact that the effective capacity of a battery depends on the rate at which it is discharged. Battery capacity is normally quoted at the 20 hour discharge rate. Thus, a 20 ampere hour battery would be capable of providing one amp for 20 hours. However, it would not be capable of providing 20 amperes for one hour. The de-rating is needed in cases

in which the alarm current is sufficiently high to reduce the effective capacity below its nominal value.

Where $C_{\text{MIN}}/20$ will be equal to or greater than I_2 , it can be assumed that $D = 1$. When $C_{\text{MIN}}/20$ is less than I_2 , the value of D should either be based on the battery manufacturer's data or should be 1.75.

Example 1: Category M or Category L System

Consider premises that are unoccupied from 6.00 pm Friday until 9.00 am Monday. Assume the normal operating current of the system is 350mA and the maximum alarm load is 2.0A. The capacity of the standby batteries would be:

$$1.25 (24 \times 0.35 + 2 \times 1.75 \div 2) = 12.7\text{Ah.}$$

The next highest available capacity size should be used.

If, however, the circuit serving the fire alarm system is served by an automatically started standby generator, the capacity can be reduced to:

$$1.25 (6 \times 0.35 + 2 \times 1.75 \div 2) = 4.8\text{Ah}$$

part one | guide to design of fire systems

power supplies

Example 2: Category P System

As the premises are unoccupied for 63 hours, a battery having capacity to operate the system for 72 hours is required. Accordingly, the required battery capacity would be:

$$1.25 (72 \times 0.35 + 2 \times 1.75 \div 2) = 33.7\text{Ah.}$$

Again, the next highest available size should be used.

part one | guide to design of fire systems

cabling considerations

12. Cabling Considerations

Correct operation of a fire alarm system depends on the interconnections between the control equipment, detectors, call points and sounders. Unless these interconnections operate correctly when required, the system will not fulfil its intended functions.

The components of most fire detection and alarm systems are connected by cables. For specialised applications where cabling cannot be used, fibre optics and/or radio links are used. Clause 27 of BS 5839-1 covers radio-linked systems. These systems are 'wireless', in that all communications between control equipment and devices (manual call points, detectors and sounders) is carried out using radio transmission.

When selecting cables for a fire alarm system due consideration should be given to the following:

1. Resistance to fire
2. Current carrying capacity.
3. Voltage drop under maximum current conditions.
4. Insulation characteristics.
5. Mechanical robustness, resistance to corrosion and rodent attack, etc.
6. Screening (where applicable).
7. Suitability for carrying data (where applicable).

Although a wide variety of different cables could be used in various parts of a fire alarm system, many may be restricted in their suitability because of their varying abilities to resist both fire and mechanical damage. All cables used in fire detection and alarm systems (including those serving the mains supply to the system) must be fire resisting. The recommended cable types are described in the following subsection.

12.1 Recommended Cable Types

The type of cable, its routing and its physical and electrical protection characteristics should be specified for each particular installation. Wiring, in general, must comply with the latest issue of BS 7671 Requirements for Electrical Installations - IEE Wiring Regulations (currently Seventeen Edition). Wiring for specific systems should also conform to BS 5839-1: 2002.

part one | guide to design of fire systems

cabling considerations

Cables used throughout the system (including that used for the final circuit providing mains voltage to the system) should comprise only one of the following types of cable:

- 1) Mineral insulated copper sheathed cables. Conforming to BSEN 60702-1 and BSEN 60702-2
- 2) Proprietary fire resisting cables that conform to BS 7629 (these are sometimes described as 'soft skinned' fire resisting cables).
- 3) Armoured fire resisting cables conforming to BS 7846.
- 4) Cables rated at 300/500V (or greater) and that provide the same degree of safety to that afforded by cables complying with BS 7629.

BS 5839-1 divides fire resisting cables into two categories, described as standard fire resisting cables and enhanced fire resisting cables.

12.2 Cable Suitability

For some applications, such as those listed below, the code recognizes that the level of fire resistance described as 'enhanced' is desirable:

- 1) in unsprinklered buildings (or parts of buildings) in which the fire strategy involves evacuation of occupants in four or more phases;
- 2) in unsprinklered buildings of greater than 30m in height;
- 3) in unsprinklered premises and sites in which a fire in one area could affect cables of critical signal paths associated with areas remote from the fire, in which it is envisaged people will remain in occupation during the course of the fire. Examples may be large hospitals with central control equipment and progressive horizontal evacuation arrangements, and certain large industrial sites;
- 4) in any other buildings in which the designer, specifier or regulatory authority, on the basis of a fire risk assessment that takes fire engineering considerations into account, considers that the use of enhanced fire resisting cables is necessary.

It should be noted that, in the first three specific cases, sprinkler protection would obviate the need for use of cables of en-

part one | guide to design of fire systems

cabling considerations

hanced fire resistance. It is considered that, in a sprinklered building, the fire risk, the likelihood of fire development and the likely exposure of cables to fire make the use of cables of standard fire resistance acceptable. However, for the purpose of this recommendation, a building should be regarded as sprinklered only if an automatic sprinkler installation is provided throughout the building.

The reason for the use of enhanced fire resisting cables in unsprinklered buildings in which there is evacuation in four or more phases is simply that, in these situations, occupants will be expected to remain in the building for some time after fire is detected. It is therefore essential that the system is capable of reliably giving warning to occupants during the very last phase of the evacuation. It is also important that there is a high reliability and that indication from other automatic fire detectors of fire spread can be given at the control and indicating equipment.

In a large building with phased evacuation, a networked fire alarm system might be provided, with several control panels interconnected by a data network. In this case, individual, self-contained fire alarm systems might serve parts of the building that are evacuated in less than four phases,

even though the entire building is evacuated in four or more phases. In these cases, cables of enhanced fire resistance need not be used for the systems themselves, but there may be a need to use cables of enhanced fire resistance for the network. However this may not be necessary if the network is configured in a loop, with diverse routing of incoming and outgoing circuits, and if the loop is designed in such a way that there will be no loss of communication to any sub-panel in the event of a single open or short circuit on the loop.

The recommendation for cables of enhanced fire resistance in unsprinklered buildings of greater than 30m in height simply reflects the greater risk associated with tall buildings. In those cases, phased evacuation is often used, and the recommendation relating to phased evacuation will already apply. It should also be noted that legislation normally requires new buildings of greater than 30m in height to be sprinklered, unless the buildings are of a residential or institutional nature (i.e. flats, hospitals, residential care premises, hotels, hostels, etc). It is, nevertheless, important that the recommendation for use of cables of enhanced fire resistance in unsprinklered buildings of greater than 30m in height be borne in mind when retrofitting fire alarm systems that might

part one | guide to design of fire systems

cabling considerations

not have required sprinkler protection at the time of construction.

The third situation, in which cables of enhanced fire resistance are specified above, often occurs in hospitals.

In a hospital, the principle of progressive horizontal evacuation applies. This means that, in the first stages of a fire, patients are moved horizontally, through a set of fire resisting doors, into an adjacent 'sub-compartment'. Only if the fire continues to grow and threaten this adjacent fire compartment will these patients be further evacuated. Similarly, patients in the remainder of the hospital will not be evacuated unless they are threatened by the fire.

Progressive horizontal evacuation differs from phased evacuation in that, in a phased evacuation, the intention is to evacuate all occupants in a number of discrete phases. In progressive horizontal evacuation, the intention is, if safe to do so, not to evacuate. If, subsequently, evacuation is necessary, cables required for this purpose must remain undamaged.

A similar situation to that described for hospitals can apply in complex (generally low rise) interconnected buildings. It may be unnecessary to evacuate the areas

most remote from a fire, but, equally, there may be a need for a facility to do so at an advanced stage in the fire if this becomes necessary. However, if the buildings were served by a networked system, and each of the independently evacuated sections were self-contained fire alarm system, cables of enhanced fire resistance would not be necessary except, possibly, in the case of the networked cables. If communication between buildings was required.

Thus, the considerations applicable to networked systems, described for phased evacuation buildings, apply in this situation.

What then of a large site, with many separate buildings, all served by a single fire alarm system, with cables for one or more buildings running through other buildings? This situation is not clearly addressed in the code. However, in fire safety design, account is not normally taken of a situation in which two independent fires occur at the same time. Accordingly, pragmatism would seem to dictate that, if the separation between buildings is such that, in the event of fire in one building evacuation of other buildings could not be anticipated, even at an advanced stage of the fire, the use of cables of enhanced fire resistance would seem to be unnecessary.

part one | guide to design of fire systems

cabling considerations

With regard to the fourth example in which the code recommends that cables of enhanced fire resistance should be used, the reason is that, in some fire engineering solutions, a reduction in the normal level of other fire protection measures may be acceptable to an enforcing authority, providing an automatic fire detection system is installed. In such a case, clearly the reliability of the automatic fire detection system must be of the highest order, since normal provisions for means of escape may have been relaxed. In such circumstances, the code leaves it to the enforcing authority to determine whether, as part of the fire engineering solution, cables of enhanced fire resistance will be necessary to satisfy legislation.

12.3 Conductor Sizes

When selecting conductor sizes, regard should be paid to physical strength and the limitations imposed by voltage drop. Voltage drop in a cable should not be such as to prevent devices from operating within their specification limits. Consideration should also be given to possible future extensions and some additional capacity left. For mechanical strength, cable conductors should have a cross-sectional area of not less than 1mm².

12.4 Segregation

There are four main reasons why fire alarm cables need to be segregated from the cables of other circuits. Firstly, breakdown of cable insulation of other circuits, from which fire alarm cables are not segregated, might affect the fire alarm system. Secondly, a fault on another circuit could cause the cables of that circuit to catch fire, resulting in damage to the fire alarm cables. Thirdly, electromagnetic interference from other circuits, from which there is inadequate separation distance and/or screening, could affect the operation of the fire alarm system. Finally, strip out of other cable could result in mechanical damage to the fire alarm cables.

Generally, the insulation of the cables specified for use in fire alarm systems (see 12.1) provides adequate insulation against mains voltage. Also, all acceptable cable types are fire resisting, preventing immediate damage from a fire in adjacent cables, and the cables used for fire alarm systems provide a relatively good degree of screening. Accordingly, it may be acceptable to run fire alarm cables that comply with all the above recommendations on, for example, common cable tray with mains voltage cables.

part one | guide to design of fire systems

cabling considerations

However, where practicable, fire alarm cables should not run unnecessarily long distances (e.g. more than 35m in aggregate), in close proximity to high current carrying cables, particularly if these serve high inductive loads. This is more important in the case of addressable systems than conventional systems. In order to minimize the extent to which separation from other cables is not maintained, fire alarm cables should always cross the cables of other services at right-angles.

It should also be ensured that there can be no interference between the mains voltage cables serving the fire alarm system and the lower voltage fire alarm circuits. In particular, the mains supply cable to any control, indicating or power supply equipment should not enter the equipment through the same cable entry as cables carrying extra-low voltage. Within the equipment, low voltage and extra-low voltage cables should be kept separate to the extent practicable.

Where fire alarm cables share common trunking with the cables of other services, a compartment of the trunking, separated from other compartments by a strong, rigid and continuous partition, should be reserved solely for fire alarm cables.

12.5 Cable Colour Coding

Having segregated the fire alarm circuits from other circuits and, in the case of trunking, kept the fire alarm cables within a separate compartment from other circuits, it is important that this situation is maintained. It is also important that there is no interference with fire alarm circuits as a result of confusion between these circuits and other circuits. Accordingly, the code recommends that all fire alarm cables should be of a single, common colour that is not used for cables of general electrical services in the building. While a note in clause 26 of the code states that the colour red is preferred, it would be possible to comply with the code by using another colour, provided the same colour is not used for cables of other electrical services in the building.

12.6 Joints in Cables

To ensure the integrity of the fire alarm circuits, the code recommends that cables should be installed without external joints wherever practicable. Where jointing of cables is necessary, other than in the case of joints within components of the system, the terminals used to joint the cables should be constructed of materials that will withstand a similar temperature and

part one | guide to design of fire systems

cabling considerations

duration of temperature to that of the cable itself. This recommendation precludes the use of certain plastic terminal blocks. The joints should be enclosed within junction boxes, labelled with the words 'FIRE ALARM', to assist in the identification of fire alarm circuits.

12.7 Cable Support

Consideration should be given to the type of fixings used to support and/or secure fire detection and alarm system cabling and wiring. Primarily, it is the material in which the fixings are manufactured, i.e. plastic or metal, that is of importance. There would be little point in securing alarm system cables to a wall or the underside of a tray with plastic fixings if, in the event of a fire, these were to melt and allow the cables to fall and become damaged preventing the alarm condition being given. In general, plastic cable fixings should only ever be used for fixing cables run in or on top of horizontal trays.

Metal type cable fixings should be used in all other situations. The type of fixings recommended for use in various situations are as follows:

Cables in/on Horizontal Trays

Where cables run in (or on top of) horizontal trays they should be neatly and securely fixed at suitable intervals with either plastic or metal cable ties.

Cables under Horizontal Trays

Where cables are run along the underside of horizontal trays, metal cable ties or metal P clips should be used to neatly and securely fix the cables at suitable intervals (plastic fixings must not be used).

Cables in Vertical Ducts or Shafts

Cables run in vertical ducts or shafts should be neatly and securely fixed at suitable intervals with metal cable ties or metal P clips. For long ducts and shafts, cables should be secured to staggered fixing pins so as to prevent them from stretching under their own weight.

Cables in Walls

Cables run along walls should be neatly and securely fixed at suitable intervals to metal wall brackets with metal P clips. In all other respects, the installation of cabling and wiring should be undertaken generally in accordance with BS 7671 (Requirements

part one | guide to design of fire systems

cabling considerations

for Electrical Installations - IEE Wiring Regulations, Seventeenth Edition).

12.8 Mechanical Protection of Cables

Mineral insulated copper sheathed cables and steel wire armoured cables may be used throughout all parts of the system without additional mechanical protection, except in particularly arduous conditions. The code recommends that other cables should be given mechanical protection in any areas in which physical damage or rodent attack is likely. More specifically, other than in relatively benign environments in which cable is clipped directly to robust construction, mechanical protection should be provided for these other cables in all areas that are less than 2m above floor level.

The term 'relatively benign environments' is not specifically defined, but, since the code gives the example of offices, shops and similar premises, in many situations, other than certain factories, warehouses and similar premises, it will be possible to install the so-called 'soft-skinned' cables without additional mechanical protection. However, where the environment is not 'relatively benign', additional protection to these cables will be necessary, at least, everywhere that

cables run less than 2m above floor level; it should be noted that this will include at least part of each 'drop' to a manual call point, since the latter devices are generally installed around 1.4m above floor level.

For the purposes of the above recommendation, additional protection may be provided by running the cable on cable tray, 'chasing in' within the building structure, or by installation of the cables in conduit, ducting or trunking. If, however, particularly arduous conditions might be experienced (such as impact by forklift trucks or goods trolleys), additional, robust protection is recommended by the code in the form of burying the cable in the structure of the building or installation in metal conduit or trunking.

part one | guide to design of fire systems

communication with the fire service

13. Communication with the Fire Service

When a fire occurs in an occupied building, the most important initial action is to provide a warning to all occupants. However, the immediate summoning of the fire service is also important. Accordingly, clause 15 of BS 5839-1: 2002 is concerned purely with communication with the fire service.

The code recommends that, in occupied buildings, the primary means of summoning the fire service should always comprise a call to the fire service by occupants using the public emergency call system. This manually dialled call will usually be sufficient in the case of a Category M system, since, by definition, there must be occupants in the building in order for the alarm to be raised.

Equally, even if there is a means for transmitting alarm signals automatically to an alarm receiving centre (ARC), from where the fire brigade are then summoned, if the building is occupied a manually dialled emergency call to the fire service should still be made. In some areas of the country this manually dialled call has an additional benefit, as some fire brigades dispatch

more fire appliances to a confirmed fire than to a call from an ARC.

The code recommends that the emergency call be made by a person, rather than by automatic systems that transmit a pre-recorded message direct to the fire service by the public emergency call system. In practice, the use of the now very old-fashioned 'tape 999 diallers', and even more modern equipment with digitally recorded messages, is uncommon. In any case, use of such equipment would not now comply with the code.

Often, it is pre-determined that a switchboard operator or receptionist will summon the fire brigade in the event of operation of the fire alarm system. If it is the case that an area, such as a telephone switchboard or reception desk, is specifically designated as that from which the fire service will be summoned, the code recommends that the fire alarm signal in this area should not be so loud as to interfere with telephone speech. Thus, in this area, the normal recommendations in respect of sound pressure level (see Section 9) do not apply.

13.1 Automatic Transmission of Alarm Signals

Having made suitable arrangements for immediate summoning of the fire service in the event of fire when the building is occupied, consideration should always be given to whether there is then a need for additional automatic means of transmission of alarm signals to an ARC. Accordingly, the code recommends that the designer should determine from the purchaser or user whether such a facility is required. It should be noted that the designer has not complied with the recommendations of the code unless a specific enquiry regarding the requirement for this facility is made of the purchaser or user.

Such a facility will not normally be necessary in the case of a Category M or Category L system, since the purpose of this system is purely to facilitate evacuation in the event of fire. However, there may be circumstances in which the safety of occupants does indeed depend on the early arrival of the fire service. An example of this is a hospital. The early arrival of the fire service is vital to minimise the need to evacuate patients. This may also apply to residential care premises.

The code recommends that, if the early summoning of the fire service is considered critical to the safety of occupants, facilities should be provided for automatic transmission of alarm signals to an ARC, unless there are reliable arrangements for summoning the fire service by persons in the building. The decision as to whether the early summoning of the fire service is critical to occupants' safety will often arise from a fire risk assessment.

13.1.1 Category L Systems

In the case of Category L systems, if the premises are unoccupied at certain times it can represent a missed opportunity, in respect of property protection, if no means for automatic transmission of alarm signals is provided. Certainly, under these circumstances, the cost of the facility in relation to the additional protection provided will often clearly point towards the value of the automatic transmission facility.

In some commercial premises in multiple occupation (e.g. an office building occupied by various tenants, or a small retail park with a common internal service corridor) there is no continuously manned reception or similar facility, occupied by someone who can be made responsible for summoning the fire service. The reliability

part one | guide to design of fire systems

communication with the fire service

of the arrangements for summoning the fire service might then be less than perfect. Accordingly, the code recommends that, in non-domestic premises in multiple occupation, Category L systems should incorporate an automatic means for transmission of alarm signals to an ARC, unless there are arrangements in place for summoning the fire service by occupants of the building at all times that the premises are occupied (or partly occupied).

13.1.2 Category P Systems

Since the purpose of a Category P system is to protect property, one of the primary purposes of the system is to summon the fire service. Accordingly, the code recommends that, except in the case of continuously occupied premises, all Category P systems should incorporate a means for automatic transmission of fire signals to an ARC. It should be stressed, therefore, that failure of a Category P system to incorporate such a facility constitutes a non-compliance with the code (or, if agreed with all parties, a 'variation'), unless the premises are continuously occupied.

13.2 Methods of Automatic Transmission

BS 5839-1 expresses a preference for systems in which the transmission path is continuously monitored, so that failures can be identified and the 'down time' is minimized. This implies a preference for fully monitored systems (e.g. British Telecom RedCARE) over systems that use the public switched telephone network (e.g. digital communicators). Since this preference is only expressed within the commentary, and there is not a corresponding recommendation, compliance with the code does not actually necessitate the use of monitored systems. However,

13.3 Standards for Alarm Receiving Centres (ARCs)

BS 5839-1 recommends that any ARC to which fire alarm signals are relayed should comply with the recommendations of BS 5979 Code of practice for remote centres receiving signals from security systems.

part one | guide to design of fire systems

system installation

14. System Installation

Installation is the subject of an entirely independent section of BS 5839-1: 2002, namely Section 4. Thus, Section 4 is addressed primarily to the installer of the system. The actual responsibilities imposed on the installer by the code are relatively minimal, at least in comparison with the responsibilities placed on all other relevant parties, namely the designer, the commissioning engineers and the maintenance organization.

The code stresses that it is not, in general, the responsibility of the installer to check or verify whether the design of the system complies in full with the recommendations of the code, unless, of course, the installer is also the designer. It is, therefore, very important that responsibilities for design, installation and commissioning are clearly defined and documented before an order is placed for the system.

In practice, compliance with a number of the design recommendations of the code impact on installation, and compliance may, therefore, be delegated by the designer to the installer. However, this needs to be made clear in any specification or contract, so that the installer accepts responsibility for the issues in question, and

it is necessary for the installer to be competent to address the issues in question. Such issues will, therefore, often be limited to matters that it is reasonable to expect any competent electrical contractor to address. An example is cable routes; often, these are not determined by the designer, but are left to the installer to determine. Under these circumstances, in a specification, the designer may refer to the relevant clause of the code, which could reasonably be imposed, in part, on the installer.

At the design stage, it can be very difficult for the designer to ensure compliance with all relevant recommendations of the code. The obvious example in this respect concerns sound pressure levels, and it might be reasonable, within a specification, to require that the installer carry out measurements of sound pressure level, before commissioning, so that any additional sounders required can be installed before the somewhat late stage in a project at which commissioning is carried out.

Even so, the code considers, in effect, that the designer should not glibly assume that the installer of the system will have expertise in the design of fire alarm systems. Therefore, it is the responsibility of the designer to provide sufficient information and guidance to the installer to enable the

part one | guide to design of fire systems

system installation

installer to satisfy the relevant recommendations of Section 2 of the code (which covers design).

14.1 Siting of Equipment

The installer will be responsible for fixing control, indicating and power supply equipment. The code recommends that all such equipment that is likely to need routine attention for maintenance should be sited in readily accessible locations that facilitate safe maintenance. It is further recommended in the code that all metallic parts of the installation, including conduit, trunking, ducting, cabling and enclosures, should be well separated from any metalwork forming part of a lightning protection system.

14.2 Installation Work

With regard to the actual installation work, the code expects little more than that the installer should conform to the requirements of BS 7671, albeit that, where any conflict between BS 5839-1 and BS 7671 exists (which is unlikely), BS 839-1 should take precedence. Particular conventional good practices that are highlighted in clause 37 of the code, include proper fixing of cables, so that, for example, they do not rely on suspended ceilings for their

support, avoidance of unnecessary joints, proper arrangements for earthing, with care taken to ensure the electrical continuity of electromagnetic screens, including metallic sheaths of cables.

Recommendations are also given in clause 37 for fire stopping of penetrations for cables, conduits, trunking or tray, and for fire stopping within ducts, trunking, shafts, etc that pass through floors, walls, partitions or ceilings. Recommendations are also given to ensure that cables are not damaged as they pass through penetrations in construction and that penetrations in external walls are suitably sleeved.

Clause 37 recommends consideration of some of the recommendations in Section 2 of the code. However, once again, these are primarily recommendations that relate to practical installation considerations, such as segregation, protection of cables against mechanical damage and support of cables, rather than matters of fundamental design, such as whether cables should be of standard or enhanced fire resistance; the latter issue is purely one for the designer to specify.

Generally, it is responsibility of the installer to provide 'as fitted' drawings of the system, showing the locations of equipment, cable

part one | guide to design of fire systems

system installation

routes, cable sizes and types, etc. The view taken in the code is that, by default, unless it has been agreed that the preparation of 'as fitted' drawings is to be the responsibility of others, it is the responsibility of the installer to supply these to the purchaser or user of the system. On completion of installation work, the installer should also issue a certificate of installation. Annex G of the code contains a model certificate for this purpose.

An electricity supply from a card or coin meter is unacceptable.

14.3 Inspection and Testing

Clause 38 of BS 5839-1 deals with inspection and testing of wiring. This clause is included within Section 4 of the code ('Installation') because, of course, this work is normally carried out by the installer.

In practice, any competent contractor who installs electrical wiring, whether as part of a fire alarm installation or any other form of electrical installation, will 'megger' test the wiring to confirm that the insulation resistance is adequate. The code recommends that insulation testing should be carried out at 500 V d.c., unless the cables are not rated for mains voltage; in practice, cables used within the system will be ra-

ted for mains voltage, albeit that fire alarm systems operate at extra low voltage. This initial 500 V test is useful in identifying incipient defects that might not come to light from testing at a much lower voltage and that might not be identified by the system's fault monitoring; problems might, however, arise during the lifetime of the system.

The code recommends that insulation resistance be measured between conductors, between each conductor and earth, and between each conductor and any screen. In practice, when such a test is carried out on newly installed wiring, a reading of infinity will be obtained, or, at least, the meter will indicate a higher resistance than the 100 M Ω that is often the maximum value that the meter can accurately read. Although this will invariably be achieved with properly installed and undamaged cable, such high resistance is not actually necessary for operation of the system. A certificate covering the mains supply installation should be provided.

The code recommends that the insulation resistance measured in these tests should be at least 2 M Ω . In practice, if such low insulation resistance is found in newly installed cables, it almost implies the existence of a potential fault that might result in instability in the degree of insulation

part one | guide to design of fire systems

system installation

resistance afforded. Moreover, the code does contain a 'health warning' in the form of a note that draws attention to the fact that, in large systems, the insulation resistance would need to be much higher if control and indicating equipment has a means for sensing resistance between conductors and earth, otherwise nuisance fault indications might result. On the other hand, for a small non-addressable system of up to about four zones, 2 M Ω might be acceptable.

Since the installation is an electrical installation to which BS 7671 applies, obviously, further tests should be carried out to ensure compliance with BS 7671. Thus, the code draws attention to the need for earth continuity testing and, in the case of mains supply circuits, for measurement of earth fault loop impedance.

Since the insulation resistance tests need to be carried out with equipment disconnected, further tests might need to be carried out on the final completion of the system. The code makes the installer responsible for carrying out these tests, unless there is specific agreement that they will be carried out as part of the commissioning process. In the case of an addressable system, would specify a maximum resistance for any loop. Thus, one of the

further tests recommended by the code is measurement of the resistance of any circuit for which a maximum circuit resistance is specified. As a final 'catch all', the code also recommends that the installer carry out any other tests specified by the manufacturer of the system, unless, again, there is specific agreement that these tests will be carried out as part of the commissioning process.

The results of all tests described above, should be recorded and made available to the commissioning engineer. Thus, completion of the model installation certificate contained in Annex G of the code requires that the installer confirm that wiring has been tested in accordance with the recommendations of clause 38 and that test results have been recorded. The model certificate contains space for the installer to record the person to whom these test results have been provided.

14.4 Commissioning and Handover

Commissioning and handover are the subject of Section 5 of the code. In practice the code tends to regard commissioning as merely setting the system to work and verifying that it operates correctly in the manner designed. The commissioning engineer is also expect-

part one | guide to design of fire systems

system installation

ted to ensure that installation workmanship is generally of an adequate standard and that all relevant documentation has been handed over to the user.

However, the code acknowledges that it is not, in general, the responsibility of the commissioning engineer to verify compliance of the design, or of the installation work, with the recommendations of the relevant sections of the code (i.e. Sections 2 and 4 respectively). Equally, the code recognizes that, as in the case of installation, it may be difficult to ensure that the system complies in full with certain recommendations of Section 2 until the time of commissioning; adequacy of sound pressure levels is an obvious example (unless adequacy of sound pressure levels throughout the building has been carefully checked during the installation process). Similarly, information about structural features of the building, or final layout, might not have been available to the designer. Commissioning is, in effect, the final 'safety net' for obvious shortcomings in design to be identified.

In order to commission the system properly, the commissioning engineer will need to be furnished with the specification for the system. The commissioning engi-

neer should also have a basic knowledge and understanding of Section 3 of the code, and the recommendations it makes in respect of limiting false alarms, so that he can verify compliance with, at least, the principles discussed in Section 3.

The code sets out a list of 27 matters that are to be checked during the commissioning process. These, obviously, include testing all devices in a suitable manner and confirming that the system's 'cause and effect', as specified by the designer, is correctly programmed and demonstrated as compliant with the specification; thus, it should be confirmed that, for example, every manual call point and automatic fire detector, on operation, results in the correct zone indication, correct text display (if the system is addressable), and that all plant shutdowns, etc operate correctly.

The code also recommends that sound pressure levels throughout all areas of the building are checked for compliance with the recommendations of the code. If the installation incorporates a voice alarm system, it should be confirmed that intelligibility is satisfactory. A check is also necessary to ensure that no changes to the building, since the time of original design, have compromised the compliance of the

part one | guide to design of fire systems

system installation

system with the code (e.g. by a final fit out that affects the adequacy of device siting).

As in the case of the installer, the commissioning engineer is not expected to confirm that the siting of all devices meets the detailed design recommendations of the code. For avoidance of doubt as to the commissioning engineer's responsibilities in this respect, the code specifies the particular recommendations within Section 2 that should be verified at commissioning. The recommendations that are cited relate primarily to practical considerations, such as proximity of detectors to walls, partitions, obstructions and air inlets. Similar practical considerations in the siting of control, indicating and power supply equipment are recommended for verification, along with a check that a suitable zone plan is displayed.

The commissioning engineer is also expected to inspect the mains power supplies, as far as is reasonable practicable, to ensure compliance with the recommendations of the code. The code also recommends that the commissioning engineer confirm that standby power supplies comply with the recommendations of the code for these supplies. This will require actual measurement of quiescent and alarm currents, and the

use of the formula given in Annex D of the code (see Section 11).

A check should also be carried out to ensure, as far as is reasonably practical, that the correct cable type has been used throughout the system and that installation workmanship complies with the relevant recommendations of the code. It should be noted that, at commissioning, very little of the cable may be visible, and certainly it will be difficult to confirm that every length of cable is suitably supported.

Often, batteries are not fitted until the time of commissioning. Accordingly, the code recommends that labels, visible when batteries are in their normal position, should be fixed to batteries, indicating the date of installation.

While it is not the responsibility of the commissioning engineer to verify or certify compliance of system design with the code, the code does recommend that the commissioning engineer confirm that there are no obvious shortcomings in compliance with Section 2 of the code. Thus, it would be expected that the commissioning engineer identify the existence of unprotected areas within a Category L1 or P1 system, or obvious errors in the spacing or siting of detectors.

part one | guide to design of fire systems

system installation

The code recommends that the commissioning engineer confirm that adequate records of insulation resistance, earth continuity and, where appropriate, earth loop impedance tests exist. It is also recommended that the commissioning engineer confirm that all relevant documentation has been provided to the user or purchaser; the nature of this documentation is discussed in the next section of this guide.

On completion of commissioning, a commissioning certificate should be issued. Completion of the model certificate contained in Annex G of the code requires that the commissioning engineer confirm that the system has been commissioned in accordance with the code, other than any recorded variations from the recommended commissioning process. Completion of the certificate also requires that it be confirmed that all equipment operates correctly, installation work is, as far as can be reasonably ascertained, of an acceptable standard, that there is no any obvious potential for an unacceptable rate of false alarms and that the required documentation has been provided to the user. The certificate should also record an appropriate period for which a soak test should be carried out (see Section 8). There is also space on the commissioning certificate for the commissioning engineer to record potential causes

of false alarms that, while not warranting specific action at the time of commissioning, should be considered at the time of the next service visit to determine whether false alarm problems are arising.

part one | guide to design of fire systems

documentation

15. Documentation

In a highly modular contract, in which design, installation, supply and commissioning are undertaken by a number of different parties, more than one party may be involved in provision of the documentation recommended by BS 5839-1. To address this point, the responsibility for provision of documentation needs to be defined before an order for the system is placed. In addition, the organization to which each form of documentation is provided needs to be defined in any contract for design, supply, installation and commissioning of the system. For example, some documentation might be provided to a main contractor (e.g. by an installation sub-contractor), rather than directly to the user or purchaser. Therefore, as noted in Section 14, at commissioning it needs to be ensured that, either the documentation has been provided to the relevant parties, or that any absent documentation is identified for appropriate action.

The documentation recommended by BS 5839-1 comprises the following:

- Certificates for design, installation and commissioning of the system.
- An adequate operation and maintenance (O&M) manual for the system.

- As fitted' drawings.
- A log book.
- A record of any agreed variations from the original design specification.
- Such other records as are required by any purchase specification.

Separate certificates may exist for design, installation and commissioning (i.e. if each of these processes is undertaken by a different party). If more than one of these three processes, including all three of them, are undertaken by a single party, it would be reasonable, and probably more convenient for the recipient in any case, to provide a single certificate that covers the processes for which the signatory has been responsible.

The O&M manual should provide information, specific to the system in question, and the information provided should include the following:

1. The equipment provided and its configuration.
2. Use of all controls.
3. Recommendations for investigation of a fire alarm or fault signal after the incident is over and the building is declared safe for re-occupation.

part one | guide to design of fire systems documentation

(This is not, however, intended to be the emergency or evacuation plan, which is the responsibility of the occupant to formulate.)

4. Recommendations for investigation in the event of a false alarm.
5. Routine weekly and monthly testing of the system by the user or his appointed agent.
6. Service and maintenance of the system in accordance with Section 6 of the code.
7. Avoidance of false alarms (based on the information contained in Section 3 of the code).
8. The need to keep a clear space around all fire detectors and manual call points.
9. The need to avoid contamination of detectors during contractors' activities.
10. The importance of ensuring that changes to the building, such as relocation of partitions, do not affect the standard of protection.
11. Other user responsibilities described within Section 7 of the code.

The minimum information that should be provided on all 'as fitted' drawings comprises:

1. The positions of all control, indicating and power supply equipment.
2. The positions of all manual call points, fire detectors and fire alarm devices.
3. The positions of all equipment that may require routine attention or replacement (the obvious example is short circuit isolators).
4. The type, sizes and actual routes of cables.

Cable routes shown need to comprise a reasonable representation of the route followed, such as to enable a competent person to locate the cable in the event of a fault or need for modification or extension of the system.

part one | guide to design of fire systems

maintenance

16. Maintenance

Once the system is handed over to the user, there will be a need for it to be maintained, so that it continues to provide the protection that it was designed to give. This will necessitate regular testing by the user and periodic servicing by specialists.

16.1 Routine Testing

The routine testing recommended in BS 5839-1 is not intended to overlap significantly with the benefits afforded by system monitoring. The testing that is recommended is very basic in nature, and it can be implied from the recommendations of the code that it really only has two principal functions.

The first of these is to ensure that the system has not suffered some form of catastrophic failure, such as total power failure or major circuit failure. In pursuit of this confirmation, the code recommends that, every week, just one manual call point should be operated. The purpose of this test is only to ensure that the control equipment is capable of processing a fire alarm signal, if one occurs, and can provide an output to fire alarm sounders. If there is a facility for transmission of fire alarm signals to an alarm receiving centre, it should

also be ensured that the signal is correctly received at the alarm receiving centre. To avoid any confusion between the weekly test and a genuine fire alarm signal, the code now recommends that the duration for which fire alarm sounders should operate at the time of the weekly test should not normally exceed one minute.

The second, but more subsidiary, objective of the weekly test is to make occupants familiar with the fire alarm signal. For this reason, the code specifically recommends that the weekly test should be carried out during normal working hours. It is also recommended in the code that the test be carried out at approximately the same time each week. In systems with staged alarms, incorporating an 'Alert' and an 'Evacuate' signal, the two signals should be operated, where practicable, sequentially in the order that they would occur at the time of a fire. This is to minimize the chance of confusion between the 'Alert' and 'Evacuate' signals.

In some premises, certain occupants may work only at times other than that at which the fire alarm is tested. An example would be permanent night shift workers. To ensure that these employees are also made familiar with the sound of the fire alarm system, the code recommends that, in such cases, an additional test(s) be carried out

at least once a month to ensure the familiarity of these employees with the fire alarm signal(s).

While the objective of the weekly test is not to test all manual call points at any particular frequency, as a form of 'bonus', the code recommends that a different manual call point should be used at the time of every weekly test. The purpose of this is to capitalize on the test to give some opportunity to identify a defective manual call point. Since, however, this is merely something of a bonus, the code acknowledges that, for example, in a system with 150 manual call points, each manual call point will only be tested by the user every 150 weeks. To ensure the rotation in testing manual call points, the code recommends that the identity of the manual call point used in the weekly test should be recorded in the system log book.

If an automatically started emergency generator is used as part of the standby power supply for the fire alarm system (i.e. the relaxation in battery capacity offered by the code is adopted), there will be a need for routine testing of the generator. The code recommends that, in this case, the generator is started up once each month by simulation of failure of normal power supply and operated on-load for at least

one hour, after which fuel tanks should be left filled, and oil and coolant levels should be checked and topped up as necessary.

If vented batteries are used as a standby power supply, a monthly visual inspection of the batteries and their connections should be carried out. In particular, electrolyte levels should be checked. In practice, the use of vented batteries in fire alarm systems is now uncommon, but occasionally it occurs in premises that contain large battery banks for other purposes (e.g. some power stations).

16.2 Servicing

Periodic inspection and servicing are necessary so that unrevealed faults are identified, preventive measures taken, false alarm problems identified and addressed, and that the user is made aware of any changes to the building that affect the protection afforded by the system. The last of these points is particularly important.

The periodic inspection and servicing of the system needs to be carried out by a competent person with specialist knowledge of fire detection and alarm systems. BS 5839-1 advises that this should include knowledge of the causes of false alarms. The person carrying out the work should

part one | guide to design of fire systems

maintenance

have sufficient information regarding the system and adequate access to spares.

BS 5839-1 recommends simply periodic inspection and testing of the system, rather than specifying an exact frequency at which this should be carried out. The code recommends that the period between successive inspection and servicing visits should be based upon a risk assessment, taking into account the type of system installed, the environment in which it operates and other factors that may affect the long term operation of the system. However, the code does recommend that the period between successive inspection and servicing visits should not exceed six months. If the risk assessment shows the need for more frequent inspection and servicing visits, the code recommends that all interested parties should agree the appropriate inspection and servicing schedule.

BS 5839-1 recommends annual testing of all manual call points and automatic fire detectors. The test recommended for each type of detector is a functional test. For example, it would not be sufficient to rely purely on measurement of analogue values at the control equipment of an addressable system (although the code

also recommends that these analogue values be checked every twelve months).

If quarterly servicing is adopted, 25% of all detectors can be tested at the time of each quarterly visit, so that all detectors are tested on an annual basis. If six monthly servicing is adopted, either all detectors will need to be tested at the time of each alternate visit, or 50% of the detectors would need to be tested at each service visit.

The code provides recommendations on other measures that should be carried out on a twelve monthly basis, including a visual inspection to confirm that all readily accessible cable fixings are secure and undamaged, and confirmation that the entire 'cause and effect' program of the system is correct.

17. Responsibilities of User

It is not expected that the typical user will purchase a copy of BS 5839-1. However, in the code, it is recommended that appropriate information be provided to the purchaser or user. The organization responsible for the provision of documentation needs to be identified in the fire alarm contract.

BS 5839-1 recommends the appointment of a 'responsible person'. This term is defined in the code as the person having control of the building and/or premises, whether as occupier or otherwise, or any person delegated by the person having control of the building and/or premises to be responsible for the fire alarm system and the fire procedures. The code recommends that this person be given sufficient authority to carry out the duties described in the code, and that this person should normally be the keeper of the documentation recommended in the code. The primary duty of the responsible person is to ensure that:

- The system is tested and maintained properly.
- Appropriate records are kept.
- Relevant occupants in the premises are aware

of their roles and responsibilities in connection with the fire alarm system.

- Necessary steps are taken to avoid situations that are detrimental to the standard of protection afforded by the system.
- Necessary steps are taken to ensure that the level of false alarms is minimized.

The implications of these objectives relate to testing, maintenance, keeping of documentation and proper system management. The responsible person should also ensure that the control and indicating equipment is checked at least once every 24 hours to confirm that there are no faults on the system. It is also the responsibility of the responsible person to ensure that suitable spare parts for the system are held within the premises; the code gives guidance on the nature of these.

The user should also ensure that the system receives non-routine attention (usually by specialists) as appropriate.

part one | guide to design of fire systems

responsibilities of user

This includes:

- A special inspection by any new servicing organisation when they take over responsibility for servicing the system.
- Repair of faults.
- Action to address any unacceptable rate of false alarms.
- Inspection and test of the system following any fire.
- Inspection and test of the system following long periods of disconnection.
- Modification of the system as required (e.g. to take account of changes to the building).

part two | specification
for an analogue addressable
fire system

part two | specification for an analogue addressable fire system

general requirements

1 General Requirements

1.1 The Fire Alarm contractor shall be responsible for the design, supply, installation, commissioning and maintenance of a digital addressable fire detection and alarm system.

1.2 The Fire Alarm contractor shall be capable of providing a remote alarm monitoring service with a direct communications link to the Fire Service.

1.3 The Fire Alarm contractor shall have an adequate number of competent staff trained and experienced in the design, installation, commissioning and maintenance of analogue addressable fire detection and alarm systems.

1.4 The Fire Alarm contractor should have a minimum of 10 years experience in designing, installing, commissioning and maintaining fire detection and alarm systems, at least 5 years of which must be with digital addressable systems.

1.5 The Fire Alarm contractor should be BAFE certified to either LPS1014 or SP203.

1.6 All equipment central to the operation of the analogue addressable fire alarm system shall be designed and manufactured by the company installing and commissioning the system. As a minimum requirement, this clause covers the following:

- control and indicating equipment
- repeater equipment
- addressable ancillary equipment
- power supplies and automatic point detection equipment.

1.7 The supplier shall be approved to BS EN ISO 9002 Quality system standard for the design and manufacture of the equipment referred to in clause 1.6.

1.8 The main equipment proposed for use in the analogue addressable fire detection and alarm system shall be approved by at least one of the following UK or international organisations:

- Loss Prevention Council (LPC)
- British Standards Institution (BSI)
- Underwriters Laboratories (UL)
- Vertrauen Durch Sicherheit (VDS)

part two | specification for an analogue addressable fire system general requirements

1.9 The Fire Alarm contractor shall have available a complete set of technical manuals for all equipment installed. This must cover technical specification, system design recommendations and guidelines for installation, commissioning, operating and maintaining the proposed equipment.

1.10 The Fire Alarm contractor, given reasonable notice, shall permit the buyer, or its nominated agent, to conduct a quality audit at the premises where the proposed equipment is manufactured.

1.11 All variations from this specification that the contractor proposes to make shall be clearly indicated in writing, making reference to the relevant paragraph(s) of this specification.

part two | specification for an analogue addressable fire system standards and specifications

2 Standards and Specifications

2.1 Where applicable, the fire detection and alarm system, and installation, shall comply fully with the following British Standards and/or other nominated rules and regulations:

2.2 BS 5839 Fire detection and fire alarm systems for buildings:

2.2.1 BS 5839-1:2002 Code of practice for system design, installation commissioning and maintenance.

2.2.2 BS 5839-3:1988 Specification for automatic release mechanisms for certain fire protection equipment.

2.2.3 BS 5839-5:1988 Specification for optical beam detectors.

2.2.4 BS 5839-6:1995 Code of practice for the design and installation of fire detection and alarm systems in dwellings.

2.2.5 BS 5839-8:1998 Code of practice for the design, installation and servicing of voice alarm systems.

2.2.6 BS 5839-9:2003 Code of practice for design, installation and maintenance

of emergency voice communication systems.

2.3 BS 4678-4:1999 Specification for cable trunking made of insulating material.

2.4 BS 5446-1:2000 Specification for smoke alarms.

2.5 BS 6266:2002 Code of practice for fire protection for electronic equipment installations.

2.6 BS 7273:2006 Code of practice for the operation of fire protection measures.

2.6.1 BS 7273-1:2006 Electrical actuation of gaseous total flooding extinguishing systems.

2.6.2 BS 7273-4:2007 Actuation of release mechanisms for doors.

2.7 BS 7846:2000 Electric cables. 600/1000V armoured fire resistant cables having thermosetting insulation and low emission of smoke and corrosive gases when affected by fire.

2.8 BS 7671: 2001 Requirements for electrical installations. IEE Wiring Regulations, Seventeenth (17th) Edition.

part two | specification for an analogue addressable fire system standards and specifications

2.9 BS 7807 Code of practice for design, installation and servicing of integrated systems incorporating fire detection and alarm systems and/or other security systems for buildings other than dwellings.

2.10 HTM05-03-PARTB Fire detection and alarm systems.

2.11 FIA Code of practice for category 1 aspirating detection systems.

2.12 BS EN 54 Fire detection and fire alarm systems.

2.12.1 BS EN 54-2: 1998 Control and indicating equipment.

2.12.2 BS EN 54-3: 2001 Fire alarm devices - Sounders.

2.12.3 BS EN 54-4: 1998 Power supply equipment.

2.12.4 BS EN 54-5: 2001 Heat detectors - Point detectors.

2.12.5 BS EN 54-7: 2001 Smoke detectors- Point detectors using scattered light, transmitted light or ionisation.

2.12.6 BS EN 54-10: 2002 Flame detectors - Point detectors.

2.12.7 BS EN 54-11: 2001 Manual call points.

2.12.8 BS EN 54-12: 2002 Smoke detectors - Line detectors using an optical light beam.

2.12.9 BS EN 54-16: 2008 Voice alarm control and indicating equipment.

2.12.10 BS EN 54-17: 2005 Short-Circuit isolators.

2.12.11 BS EN 54-18: 2005 Input/output devices.

2.12.12 BS EN 54-20: 2006 Aspirating smoke detectors.

2.12.13 BS EN 54-21: 2006 Alarm transmission and fault warning routing equipment.

2.12.14 BS prEN 54-23 Fire alarm devices - Visual alarm devices.

2.12.15 BS EN 54-24: 2008 Components of voice alarm systems – Loudspeakers.

2.12.16 BS EN 54-25: 2008 Components using Radio Links.

part two | specification for an analogue addressable fire system standards and specifications

- 2.12.17 BS prEN 54-26 Point fire detectors using carbon monoxide sensors.
- 2.12.18 BS prEN 54-27 Duct Smoke Detectors.
- 2.12.19 BS prEN 54-29 Multi-sensor fire detectors - Point detectors using a combination of smoke and heat sensors.
- 2.12.20 BS prEN 54-30 Multi-sensor fire detectors - Point detectors using a combination of carbon monoxide and heat sensors.
- 2.13 BS 9999-2008 Code of practice for fire safety in the design management, and use of buildings.
- 2.14 BS EN 50200 Method of test for resistance to fire of unprotected small cables for use in emergency circuits.
- 2.15 BS EN 50281-1-2:1999 Electrical apparatus for use in the presence of combustible dust-Selection, installation and maintenance.
- 2.16 BS EN 60079-14:1997 Electrical apparatus for explosive gas atmospheres-Electrical installations in hazardous areas (other than mines).
- 2.17 BS EN 60702 Mineral insulated cables and their terminations with a rated voltage not exceeding 750V.
- 2.18 BS EN 60702-1 Cables.
- 2.19 BS EN 60702-2 Terminations.

part two | specification for an analogue addressable fire system control and indicating equipment

3 Control and Indicating Equipment

3.1 General Requirements

3.1.1 The control and indicating equipment shall form the central processing unit of the system, receiving and analysing signals from fire sensors, providing audible and visual information to the user, initiating automatic alarm response sequences and providing the means by which the user interacts with the system.

3.1.2 The control and indicating equipment shall be modular in construction to allow for future extension of the system.

3.1.3 The control and indicating equipment shall be easily configurable so as to meet the exact detection zone and output mapping requirements of the building.

3.1.4 The control and indicating equipment shall be microprocessor based and operate under a multitasking software program. Operating programs and configuration data must be contained in easily up-datable non-volatile memory (EEPROM). The use of 'burnt' EPROM's will not be permitted.

3.1.5 The control and indicating equipment shall incorporate a real-time clock to enable events to be referenced against time and date. This clock shall be accurate to within 1 minute per year under normal operating conditions. The clock must have the facility to compensate for time changes due to summer and winter daylight saving.

3.1.6 It shall be possible for an engineer to perform configuration updates on site by plugging a portable personal computer into the control and indicating equipment. Configuration data shall be retained on the personal computers hard drive and be capable of being backed up on to a central storage system.

3.1.7 The company responsible for the installation shall operate an approved document control system for the retention of configuration data.

3.1.8 The control and indicating equipment shall meet the requirements of BS EN 54 part 2 and BS EN 54 part 4 and shall be approved, together with associated ancillary equipment, by a UKAS accredited (or equivalent) third party certification body.

3.1.9 The control and indicating equipment shall comprise separate processors, cross-monitoring each others co-

part two | specification for an analogue addressable fire system control and indicating equipment

rect operation, for the major functions of the systems. In particular, different processors must be used for the main control function, the detection input and alarm output functions, and the display and control function.

3.1.10 The controller shall have the capacity to run up to 1000 addressable devices.

3.1.11 The address code for each addressable device shall be held within the addressable device (ie. detector head, ancillary module, callpoint etc).

3.1.12 Programming of the address code shall be via either the control and indicating equipment or a dedicated programming tool.

3.1.13 The control and indicating equipment shall incorporate a keyswitch to prevent unauthorised use of the manual controls.

3.1.14 The control and indicating equipment shall have an on-board LCD display with not less than 16 lines of text.

3.2 System Configuration

3.2.1 The control and indicating equipment shall be capable of operating with

any of the following types of automatic detection equipment:

- conventional detectors
- digital addressable detectors

3.2.2 The control and indicating equipment shall be capable of operating with intrinsically safe conventional detectors and digital addressable detectors suitable for installation in hazardous areas. These devices shall be ATEX approved.

3.2.3 Addressable input and output devices shall be connected to addressable loops capable of accepting up to 250 devices.

3.2.4 The control and indicating equipment shall have a minimum capacity for operating 1 fully loaded addressable loop. This shall be extendible up to a maximum capacity of 8 addressable loops.

3.2.5 Provision shall be made for each addressable loop to be sub-divided into a maximum of 240 geographical zones. The section of wiring corresponding to each zone circuit shall be protected from faults in other sections by line isolator modules.

3.2.6 It shall be possible to allocate all 250 addressable devices on the loop to a single zone.

part two | specification for an analogue addressable fire system control and indicating equipment

3.2.7 In order to facilitate re-configuration and system extension, the allocation of addresses to devices shall be independent of their physical arrangement on the loops.

3.2.8 In order to facilitate re-configuration and system extension, the user must (after suitable training) be able to carry out the following functions from the front of the control and indicating equipment.

- change panel text
- change zone text
- change sector text (for networked systems)
- change individual point text
- add addressable devices
- delete addressable devices
- modify addressable devices
- change individual point addresses

These functions must be restricted by the use of a high level pass code as described in 3.4.9.

3.2.9 The control and indicating equipment shall have provision to drive and monitor up to 6 repeater panels providing a repeat of the indications on the control and indicating equipment display and also incorporating the full set of system manual user controls.

3.2.10 The control and indicating equipment shall have provision to house the ac mains power supply and batteries required to power systems of up to 80 zones. Zonal indication shall be provided by the use of LED's.

3.2.11 The control and indicating equipment shall have provision for the connection of external power supplies, either local to the control and indicating equipment or distributed throughout the system, to supply power in excess of that stated in clause.

3.2.12 The control and indicating equipment shall have provision for the connection of an 80 character line printer, either locally via a parallel port or remotely via a serial port.

3.2.13 The control and indicating equipment shall be capable of interfacing directly to an electronic radio paging system.

3.2.14 The control and indicating equipment shall be capable of being interfaced with other similar control and indicating equipment without locking up or being affected by feedback signals.

3.2.15 It shall be possible to connect a PC to the control and indicating equip-

part two | specification for an analogue addressable fire system control and indicating equipment

ment to display the information that would otherwise appear on the printer referred to in clause 3.2.11.

3.2.16 The control and indicating equipment shall have the facility to enable an on board communications module to be added to allow local area networking to other controllers.

3.2.17 The control and indicating equipment shall be capable of interfacing with third party equipment via a MODBUS interface.

3.3 Mechanical Design

3.3.1 The housing(s) containing the control and indicating equipment shall be of metal construction and no greater in size than 458 mm (wide) x 580 mm (high) x 209 mm (deep).

3.3.2 The housings shall be capable of being surface or semi-recessed mounted and shall come complete with cable entries, fixings, knock-outs and covers.

3.3.3 The display component of the control and indicating equipment shall be mounted on a hinged front cover that must not open at an angle greater than 90 degrees to prevent cover damage.

3.3.4 The housings shall afford a minimum ingress protection to IP30.

3.3.5 It shall not be possible to open the control and indicating equipment without the use of a special tool.

3.3.6 The enclosure shall be manufactured from steel or die cast aluminium. No plastic parts shall be permitted.

3.4 Basic System Functions

3.4.1 The control and indicating equipment shall monitor the status of all devices on the addressable loops for fire, short-circuit fault, open-circuit fault, incorrect addressing, unauthorised device removal or exchange, pre-alarm condition and contaminated detector condition.

3.4.2 The control and indicating equipment shall monitor the status of all internal connection and interfaces, including charger, battery and remote signalling functions.

3.4.3 The control and indicating equipment shall provide the following discrete visual indications:

part two | specification for an analogue addressable fire system control and indicating equipment

3.4.4 The control and indicating equipment shall also provide at least one yellow LED which can be configured to operate to suit site specific functions.

3.4.5 In addition to the indications provided in clauses 3.4.3 and 3.4.4, the control and indicating equipment shall also have an integral 16x40 character LCD alphanumeric display.

3.4.6 The control and indicating equipment shall provide a set of push button controls to enable an authorised operator to perform the following:

- EVACUATE (actuates ALL alarm sounders in the system)
- SILENCE (stops all currently actuated alarm sounders)
- RESOUND (re-actuates the alarm sounders)
- RESET (returns the control and indicating equipment to quiescent condition)
- SILENCE BUZZER (stops the internal panel sounder)

INVESTIGATE DELAY (delays the activation of certain functions for a maximum of 10 minutes while an on-site investigation is carried out)

3.4.7 To prevent unauthorised access or accidental operation of the buttons described in clause 3.4.6, the control and indicating equipment shall incorporate an access keyswitch. This keyswitch shall inhibit the use of all the push buttons with the exception of the SILENCE BUZZER control.

3.4.8 The control and indicating equipment shall provide a facility to manually check all the discrete LED indicators and the LCD display.

3.4.9 The control and indicating equipment shall provide a simple to operate keypad to enable a user to access the various built-in functions, and interact with the information displayed on the LCD. For security reasons, the control and indicating equipment shall provide a configurable password code facility. The control and indicating equipment shall be capable of providing 99 user access codes

part two | specification for an analogue addressable fire system control and indicating equipment

each of which can be set to one of twelve access levels. The access levels should generally be described as:

- Customer Operator
- Customer Manager
- Engineer
- Commissioning Engineer
- Engineer Supervisor
- Engineer R & D

3.4.10 The control and indicating equipment shall provide facilities to drive visual indication LED mimic displays for each of the following zonal status:

- Alarm
- Fault
- Isolated

3.4.11 The control and indicating equipment shall provide facilities for signalling the following system conditions to a remote (ARC) and/or an on-site monitoring centre:

- Alarm
- Pre-alarm
- Fault
- Zone Isolated

3.4.12 The control and indicating equipment shall be capable of monitoring and controlling remote site devices, such as door release units and relays for the con-

trol of plants and dampers, directly from the addressable loops.

3.4.13 The control and indicating equipment shall be capable of monitoring fire doors in accordance with BS 7273 Part 4, such that, in the event of a fire alarm condition, an event is generated to warn of the failure of a fire door to close.

3.4.14 The control and indicating equipment shall provide programmable outputs to activate emergency lighting in the event of a mains supply failure.

3.5 Alarm Monitoring Functions

3.5.1 The control and indicating equipment shall interrogate each addressable device at least once every 5 seconds.

3.5.2 The control and indicating equipment shall incorporate fire decision algorithms specifically adapted to the response characteristics of the digital addressable detectors employed. Algorithm processing in each detector will not be permissible.

3.5.3 The algorithms mentioned in clause 3.5.2 shall perform a trend analysis of the signal received from the digital addressable detectors in order that non-fire events may be differentiated.

part two | specification for an analogue addressable fire system control and indicating equipment

3.5.4 The control and indicating equipment shall be designed so that, for each type of digital addressable detector, the overall response time, including that for the sensor, the signal transmission system and the fire decision algorithm, meets the requirement of the relevant part of EN54.

3.5.5 The response time of the control and indicating equipment to two-state addressable detectors and conventional detectors shall not exceed 10 seconds.

3.5.6 The control and indicating equipment shall have a special scanning sequence so that designated manual call points provide alarm indication and warning within 3 seconds of operation.

3.5.7 The control and indicating equipment shall have a facility to automatically adjust the sensitivity of addressable detectors to a higher level for periods of time when the building is unoccupied.

3.5.8 The control and indicating equipment shall have, as an optional software enhancement, the ability to annunciate a pre-alarm condition designed to give the earliest possible warning of a potential fire condition without raising the full alarm condition.

3.5.9 The control and indicating equipment shall have, as standard, the ability to automatically adjust the alarm and pre-alarm threshold levels to compensate for changes in detector sensitivity due to contamination over a period of time.

3.5.10 The control and indicating equipment shall have, as standard, the ability to provide automatic warning that a detector has reached a level of contamination which requires that it be replaced or serviced.

3.5.11 The control panel shall have the ability to display the levels returned from the sensors in a meaningful way. i.e. temperature in degrees C, smoke in %/m and carbon monoxide in ppm.

3.6 Alarm Output Functions

3.6.1 The control and indicating equipment shall provide the necessary outputs to separately operate two monitored circuits of common system sounders. Each output shall be capable of driving a sounder load of up to 500mA.

3.6.2 The control and indicating equipment shall be able to monitor and control the integrity of zonal sounder circuits, via a suitable addressable module.

part two | specification for an analogue addressable fire system control and indicating equipment

3.6.3 The control and indicating equipment shall be capable of providing a two-stage alarm sounder facility that can be programmed, either on a zonal basis or common system basis. Three possible sound output signals shall be available as follows:

- Alert pulsed tone (1 second ON, 1 second OFF)
- Evacuate continuous tone
- User definable tone for specialised events, for example bomb alert.

3.6.4 The control and indicating equipment shall have the facility to change, on a per sounder zone basis, the sound output signal dependent upon whether the source of alarm is:

- an automatic detector
- a manual call point
- an EVACUATE command
- a non-fire event (for example plant alarm etc.)

3.6.5 The control and indicating equipment shall be capable of generating client definable time delay sequences to upgrade alarm sounder responses, without the need for external timers, as follows:

- Silent to Alert
- Alert to Evacuate
- Silent to user defined tone.

3.6.6 The control and indicating equipment shall provide an interface to drive a public address system. The signal from the fire system to the PA/VA system shall be dual path such that, in the event of a failure of the primary signal the public address system defaults to a full evacuation of the protected premises.

3.6.7 The control and indicating equipment shall have the ability to delay the transmission to the Fire Brigade of fire alarm signals from automatic detectors in pre-determined detection zones. The time delay shall be configurable normally up to a maximum time of 2 minutes, but with the capability of being extended to 10 minutes if required.

3.6.8 The control and indicating equipment shall provide the facility to automatically inhibit the delay function described in clause 3.6.7 when the building is unoccupied.

3.6.9 The facility described in clause 3.6.7 shall not apply to alarms generated by manual call points which shall always be transmitted immediately.

part two | specification for an analogue addressable fire system control and indicating equipment

3.7 Supervision and Fault Reporting

3.7.1 The control and indicating equipment shall monitor all critical system components and interconnections (internal and external). In the event of a failure occurring which prevents correct operation of the alarm functions, a FAULT indicator will light and a message shall be given on the alphanumeric display within 100 seconds of occurrence.

3.7.2 The following faults shall be reported in the manner described in clause 3.7.1:

- Loop Short Circuit
- Loop Open Circuit
- Unconfigured Device
- Addressable Device Failure
- Device Not Responding
- Incorrectly Configured Device
- Detector Condition Monitoring Warning
- Conventional Call Point Wiring Open Circuit
- Conventional Call Point Wiring Short Circuit
- Conventional Detector Circuit Wiring Fault
- Repeater/Repeater LCD, Remote Printer Failure
- PSU Fault
- Charger Fault

- Battery Fault
- Battery Critical
- Mains Failure
- Auxiliary PSU Failure
- Relay Output Inoperative
- Signalling Fault
- Sounder Wiring Open Circuit
- Sounder Wiring Short Circuit

3.7.3 To help rapid fault finding and repair, the control and indicating equipment shall provide text messages to indicate the precise location of where a fault has occurred in the system.

3.7.4 The control and indicating equipment shall be capable of monitoring and indicating the status of auxiliary units, such as a remote signalling transmitter. This shall be achieved using a suitable addressable contact monitor module.

3.7.5 With respect to clause 3.7.4, the control and indicating equipment shall have the facility to delay the generation of an event to confirm operation of the monitored device. This shall be either 6 seconds for normal de-bounced contacts, or 40 seconds for fluctuating contacts, e.g. sprinkler flow valve switches.

part two | specification for an analogue addressable fire system control and indicating equipment

3.8 System Management Facilities

3.8.1 The control and indicating equipment shall incorporate the following system management facilities:

- Isolate/de-isolate a particular addressable point
- Isolate/de-isolate a particular detector zone
- Isolate/de-isolate a particular sounder zone
- Walk-test of a selected zone to verify detectors and sounders
- View the number of alarms since power up
- View the number of software initialisations since power up
- View common alarm status
- View common fault status
- View common disabled status
- View zonal alarm status
- View zonal fault status
- View zonal isolated status
- View point address status
- View / print full event log
- View / print filtered event log
- View / print points isolated
- Print a list of dirty detectors
- Print point statuses

3.8.2 Access to the facilities described in clause 3.8.1 shall be restricted to Customer Manager access level or above.

3.8.3 The control and indicating equipment shall have an event log capable of storing up to the last 3000 events that have occurred. It shall be possible to view the content of the log via the alphanumeric display. Events shall be displayed in chronological order in any of the following three options:

- Newest event first
- Oldest event first
- Highest priority event first.

3.8.4 The control and indicating equipment shall be capable of providing audible and visual warning when a weekly system test, as defined in BS 5839 -1: 2002, is required.

3.8.5 The control and indicating equipment shall be capable, via a suitable timer unit, of isolating a group of selected detectors in areas of the building where maintenance work is carried out. The detectors shall be automatically re-instated after a pre-determined time.

part two | specification for an analogue addressable fire system control and indicating equipment

3.8.6 The control and indicating equipment shall have a facility to enable the user to easily change the time and date settings of the system real-time clock.

3.8.7 It shall be possible to provide short circuit wiring fault isolation to every detector on the loop.

3.9 Technical Specification

3.9.1 The boxes used to house the control and indicating equipment, standard system power supply and standard repeater panel shall not exceed the following overall dimensions:

Height: 580 mm
Width: 458 mm
Depth: 209 mm

3.9.2 The overall weight of the control and indicating equipment, standard power supply unit and standard repeater unit shall not exceed 16Kg (weight of batteries excluded).

3.9.3 The control and indicating equipment shall operate on a mains power supply of:

240Vac +10% -6% @ 50 Hz \pm 2 Hz or
115Vac +15% -10% @ 50/60 Hz

3.9.4 The control and indicating equipment, standard power supply unit and standard repeater unit shall comply with the following environmental conditions:

Operating temperature range:
-8 C to +55 C

Storage temperature:
-20 C to +70 C

Relative humidity:
up to 95% RH (non-condensing)

IEC protection category:
IP30 minimum

3.9.5 The control and indicating equipment, standard power supply unit and standard repeater unit shall comply with, at least, the EMC requirements described in BS EN 54 part 2 and BS EN 54 part 4.

part two | specification for an analogue addressable fire system

automatic fire detectors

4 Automatic Fire Detectors

4.1 General Requirements

4.1.1 The Fire Alarm contractor shall have available the following types of automatic detectors for direct connection to the system addressable loops:

- Triple sensing detection (heat, optical smoke & carbon monoxide)
- Ionisation smoke detectors
- Optical smoke detectors
- High Performance Optical smoke detectors
- Infra-red flame detectors
- Heat detectors
- Carbon Monoxide fire detectors
- Aspirating smoke detectors
- High Performance Optical smoke detector for hazardous areas
- Infra-red flame detectors for hazardous areas
- Infra-red array flame detectors
- Heat detectors for hazardous areas
- Linear heat detection
- Multi sensor fire detectors

4.1.2 The Fire Alarm contractor shall have available the following types of conventional automatic detectors, manual call

points and ancillary units for connection to the system via suitable interfaces:

- Ionisation smoke detectors
- Optical smoke detectors
- High Performance Optical smoke detectors
- Infra-red flame detectors
- Infra-red array flame detectors
- Heat detectors
- Carbon Monoxide fire detectors
- Optical beam smoke detectors
- Aspirating smoke detectors
- Linear heat detection

4.1.3 The automatic fire detectors shall be fixed to the installation by mean of plug-in detector bases. Both the addressable and conventional detectors shall use a common base to simplify future upgrades.

4.1.4 The bases specified in clause 4.1.4 shall incorporate the optional feature of being able to lock the detectors in place once plugged in.

4.1.5 Addressing of any devices directly connected to the system will be carried out in a manner that does not require manual setting of switches, or the use of programming cards, in either the head or the base.

4.1.6 Addressable detectors must be able to transmit to the control and indica-

part two | specification for an analogue addressable fire system automatic fire detectors

ting equipment a pre-set and unique identifier to detect unauthorised changes in the system configuration.

4.1.7 The Fire Alarm contractor shall produce standard accessories for installing smoke detectors in air ducts. This equipment shall be designed to accommodate the manufacturer's standard smoke detectors and bases, both conventional and addressable.

4.1.8 It must be possible to connect and mix automatic detectors, manual call points and addressable modules within the same zone sub-division of an addressable loop.

4.1.9 The Fire Alarm contractor shall have available suitable equipment to test and exchange all four main types of automatic detectors.

4.1.10 The Fire Alarm contractor shall have available intrinsically safe versions of all four types of automatic detectors, the plug-in bases and the line isolator.

4.1.11 It shall be possible to connect several circuits of intrinsically safe addressable devices to a standard addressable loop via standard BASEEFA approved safety barriers and interfaces from the loop as spurs.

4.1.12 The intrinsically safe devices specified in clause .

4.1.13 shall be designed to comply with EN50014 and EN50020 and be ATEX certified by BASEEFA to EEx ia IIC T5.

4.1.14 The intrinsically safe devices shall be ATEX certified for both gas and dust environments making them suitable for use in Zone 20 and 21 areas.

4.1.15 All equipment connected to the system addressable loops, either directly or via interfaces, shall be proofed against electrical noise, high frequency pulses and electromagnetic influences from other equipment.

4.1.16 The conventional / addressable detector base shall be capable of driving a separate alarm LED indicator module. Despite being connected to a specific detector, this LED indicator module must be capable of being programmed to respond to any single detector or a group of detectors as required.

4.1.17 The operating mode of the detectors must be capable of being easily changed to suit the environment / risk present. This should be possible using timers,

part two | specification for an analogue addressable fire system automatic fire detectors

external inputs or from the front of the control and indicating equipment.

- A1R Rate of rise heat
- Combined heat and CO
- Toxic gas

4.2 Triple Sensing Detection

4.2.1 The triple sensing detectors shall be a combination heat, optical smoke and carbon monoxide detection capable of detecting a large range of fires whilst retaining false alarm resilience.

4.2.2 The optical smoke detection shall be designed in accordance with the functional requirements of BS EN 54 part 7.

4.2.3 The heat detection shall be designed in accordance with the functional requirements of BS EN 54 part 5.

4.2.4 The triple sensing detectors shall be approved and listed by the Loss Prevention Certification Board (LPCB) or Vds..

4.2.5 The triple detector shall be capable of being configured as one or more of the following operating modes.

- High false alarm resilience (employing all three detection technologies)
- Universal (employing all three detection technologies)
- High performance optical

4.2.6 The toxic gas mode shall comply with the requirements of EN50291.

4.2.7 The triple detector shall be capable of operating as a single address employing all three detection technologies and as a multiple addressed device using 3 addresses. Using 3 addresses, the detector shall be capable of operating as a fire, smoke and CO toxic gas detector simultaneously.

4.2.8 When employing all three detection technologies the operation of the optical chamber in the triple detector shall be enhanced by the presence of CO and/or heat.

4.2.9 Each detection technology shall be monitored individually such that the failure of a single detecting element must not affect the operation of the remaining two elements.

4.2.10 The optical chamber within the triple detector shall employ the pedestal principle to enhance the monitoring of the chamber and the detector ability to detect both thin burning white smoke and thick black smoke.

part two | specification for an analogue addressable fire system automatic fire detectors

4.2.11 The smoke sampling within the optical smoke chamber shall be designed to prevent small insects from creating nuisance alarms.

4.2.12 The triple detectors shall include RFI screening and feed-through connecting components to minimise the effect of radiated and conducted electrical interferences.

4.2.13 The Fire Alarm contractor shall have available the following versions of the triple detector to meet different applications:

- Digital addressable (adjustable sensitivity)

4.2.14 The triple detector shall incorporate an LED, clearly visible from ground level at all angles. The LED's shall pulse to indicate they are communicating and will light permanently when in alarm. For any areas where complete darkness is required, it shall be possible to programme individual detector LED's not to pulse during the quiescent state.

4.3 Ionisation Smoke Detectors

4.3.1 The ionisation smoke detectors shall be capable of detecting visible and invisible combustion gases emanating from fires.

4.3.2 The ionisation smoke detectors shall meet the requirements of BS EN 54 part 7.

4.3.3 The ionisation smoke detectors shall be approved and listed by the Loss Prevention Certification Board (LPCB) or Vds.

4.3.4 The ionisation smoke detectors shall use a dual ionisation chamber in which the air is ionised by a single radioactive source.

4.3.5 The radioactive source employed shall have an emission rating of less than 38 Kbcq.

4.3.6 The ionisation smoke detectors shall be designed to have high resistance to contamination and corrosion.

4.3.7 The ionisation detectors shall include RFI screening and feed-through connecting components to minimise the effect of radiated and conducted electrical interferences.

4.3.8 The ionisation smoke detectors shall be suitable for operation in wind speeds of up to 5 m/s.

part two | specification for an analogue addressable fire system automatic fire detectors

4.3.9 The ionisation smoke detectors shall incorporate screens to minimise the effect of small insects.

4.3.10 The Fire Alarm contractor shall have available the following versions of the ionisation smoke detector to meet different applications:

- Digital addressable (adjustable sensitivity)
- Conventional

4.3.11 The ionisation smoke detector shall incorporate an LED, clearly visible from ground level at all angles. The LED's shall pulse to indicate they are communicating and will light permanently when in alarm. For any areas where complete darkness is required, it shall be possible to programme individual detector LED's not to pulse during the quiescent state.

4.4 Optical Smoke Detectors

4.4.1 The optical smoke detectors shall be capable of detecting visible combustion gases emanating from fires.

4.4.2 The optical smoke detectors shall meet the requirements of BS EN 54 part 7.

4.4.3 The optical smoke detectors shall be approved and listed by the Loss Prevention Certification Board (LPCB) or Vds..

4.4.4 The optical smoke detectors shall employ the forward light-scatter principle, using optical components operating at a wavelength of 4.35nm.

4.4.5 The design of the optical smoke detector sensing chamber shall be optimised to minimise the effect of dust deposits over a period of time.

4.4.6 The optical smoke chamber shall be designed to prevent all but the smaller insects from entering the sensing chamber.

4.4.7 The optical smoke detectors shall incorporate a fin structure designed to totally eliminate the effect of very small insects such as thunder flies.

4.4.8 The optical smoke detectors shall be designed to have high resistance to contamination and corrosion.

4.4.9 The optical smoke detectors shall include RFI screening and feed-through connecting components to minimise the effect of radiated and conducted electrical interferences.

part two | specification for an analogue addressable fire system automatic fire detectors

4.4.10 The Fire Alarm contractor shall have available the following versions of the optical smoke detector to meet different applications:

- Digital addressable (adjustable sensitivity) - Intrinsically safe
- Digital addressable (adjustable sensitivity) - Intrinsically safe
- Conventional
- Conventional - Intrinsically safe

4.4.11 The optical smoke detector shall incorporate an LED, clearly visible from ground level at all angles. The LED's shall pulse to indicate they are communicating and will light permanently when in alarm. For any areas where complete darkness is required, it shall be possible to programme individual detector LED's not to pulse during the quiescent state.

4.5 High Performance Optical Smoke Detectors

4.5.1 The high performance optical smoke detectors shall be capable of detecting visible combustion gases emanating from fires.

4.5.2 The high performance optical smoke detectors shall be designed in

accordance with the functional requirements of BS EN 54 part 7.

4.5.3 The high performance optical smoke detectors shall be approved and listed by the Loss Prevention Certification Board (LPCB) or Vds.

4.5.4 The high performance optical smoke detectors shall employ the forward light-scatter principle, using optical components operating at a wavelength of 4.35 nm.

4.5.5 The high performance optical detectors shall monitor and use rapid changes in temperature to increase the normal sensitivity of the light-scatter optical sensor to obtain an improved response to fast burning fires.

4.5.6 The high performance optical smoke detector shall be capable of operating as a single address employing both detection technologies and as a multiple addressed device using 2 addresses. Using 2 addresses, the detector shall be capable of operating as a heat detector and a smoke detector simultaneously thus providing alarm verification in a single detector.

part two | specification for an analogue addressable fire system automatic fire detectors

4.5.7 In single address mode, the high performance optical detectors shall not generate an alarm condition from a rate of rise of temperature or absolute temperature alone.

4.5.8 The design of the high performance optical smoke detector sensing chamber shall be optimised to minimise the effect of dust deposits over a period of time.

4.5.9 The optical smoke chamber shall be designed to prevent all but the smaller insects from entering the sensing chamber.

4.5.10 The high performance optical smoke detectors shall incorporate a fin structure designed to eliminate the effect of very small insects such as thunder flies.

4.5.11 The high performance optical smoke detectors shall be designed to have high resistance to contamination and corrosion.

4.5.12 The high performance optical smoke detectors shall include RFI screening and feed-through connecting components to minimise the effect of radiated and conducted electrical interferences.

4.5.13 The Fire Alarm contractor shall have available the following versions of the

high performance optical smoke detector to meet different applications:

- Digital addressable (adjustable sensitivity)
- Digital addressable (adjustable sensitivity) – intrinsically safe
- Conventional
- Conventional – intrinsically safe

4.5.14 The high performance optical smoke detector shall incorporate an LED, clearly visible from ground level at all angles. The LED's shall pulse to indicate they are communicating and will light permanently when in alarm. For any areas where complete darkness is required, it shall be possible to programme individual detector LED's not to pulse during the quiescent state.

4.6 Infra-Red Flame Detectors

4.6.1 The infra-red flame detectors shall be capable of detecting infra-red radiation produced by flaming fires involving carbonaceous materials.

4.6.2 The infra-red flame detectors shall be approved and listed by the Loss Prevention Certification Board (LPCB).

part two | specification for an analogue addressable fire system automatic fire detectors

4.6.3 The infra-red flame shall be able to detect a fuel fire of 0.1 square meter area from a distance of 30 meters for the following fuels:

- Petrol (gasoline)
- N-heptane
- Kerosene
- Diesel oil
- Alcohol (I.M.S)
- Ethylene glycol

4.6.4 The infra-red flame detectors shall employ narrow band optical filters that block unwanted radiation such as that emanating from the sun or tungsten filament lamps. The flame detector must be immune from direct or reflected sun radiation and from 1kW modulated radiated heat up to 1m.

4.6.5 The infra-red flame detectors shall be designed to be sensitive to modulation of the received radiation in a small range of frequencies corresponding to the flicker of flames.

4.6.6 The infra-red flame detectors shall be designed to have high resistance to contamination and corrosion.

4.6.7 The electronic assembly of the infra-red flame detectors shall be encapsulated in high resistivity epoxy resin.

4.6.8 The infra-red flame detectors shall include RFI screening and feed-through connecting components to minimise the effect of radiated and conducted electrical interferences.

4.6.9 The Fire Alarm contractor shall have available the following versions of infra-red flame detectors to meet different applications:

- Digital addressable
- Digital addressable – intrinsically safe
- Digital addressable – type ‘n’ approved
- Conventional
- Conventional – intrinsically safe

4.6.10 The infra-red flame detector shall incorporate an LED, clearly visible from the outside, to provide indication of alarm actuation.

4.7 Infra Red Array Flame Detection

4.7.1 The IR array flame detectors shall detect flames using an IR array with a resolution of 256 x 256. To protect against false alarms the flame detectors must have a wide band IR guard channel and a sunlight detector.

part two | specification for an analogue addressable fire system automatic fire detectors

4.7.2 The IR array flame detector must be capable of reporting pre-alarms and areas of interest where a heat build up is seen. It must be able to identify up to 4 distinct fires in the field of view and report the size of the effect on the sensing array and if they are getting bigger or smaller. The bigger and smaller is by inference from the size.

4.7.3 The IR array flame detectors must be able to heat the detection window to keep them clear of condensation. The detectors shall also monitor the window for cleanliness and report when the window needs to be cleaned.

4.7.4 The IR array flame detectors shall have a consistent response across their field of view (90° horizontally).

4.7.5 It shall be possible to test the detector in-situ within a hazardous environment without needing poles to reach it. The detector must be capable of being tested using an intrinsically safe hand held unit which triggers the detector to run tests of the optics (window cleanliness) and alarm function using IR sources built into the detector.

4.7.6 IR array flame detectors shall be CE marked and approved by ATEX and IECEx

for use in Gas and Dust environments as well as FM listed.

4.7.7 IR array flame detectors shall be capable of communicating via multiple outputs within the same unit. These outputs being:

- 4-20 mA, current sink or source
- Fire and Fault relays
- Two RS485 communication lines

4.7.8 As an option, in addition to the automatic detection of flames using an IR array, the detector must be capable of containing a CCTV camera in the same housing. The picture from this camera shall have highlighted on it detector status information and the location of a fire if one should be detected.

4.7.9 The IR array flame detectors shall keep a history log which should include all alarm and fault events. The detector shall log the array information for at least 5 seconds immediately prior to a fire alarm being triggered. Access to the history log shall be possible remotely from the detector via an RS485 communications bus as well as locally.

4.7.10 It shall be possible in software to mask out an area of the field of view to pre-

part two | specification for an analogue addressable fire system automatic fire detectors

vent unwanted alarms. This mask should be easily applied to an area where the detector has had an unwanted alarm as well as by the operator selecting an area manually. The use of the mask should be selectable via the PLC link, if used, so for instance the mask can be applied while a process is running but not enabled when process is not. This enables the best possible protection while eliminating unwanted alarms.

4.7.11 The detector housing should be 316L Stainless Steel and be rated at IP66/67.

4.7.12 The detector must meet the requirements for vibration endurance as stated in FMRC 3260[clause 4.9].

4.7.13 The detector shall be capable of operating in the following environmental conditions.

- Detectors without camera
- Operating temperature range: -40°C to +80°C
- Storage temperature range: -40°C to +80°C
- Relative humidity: Up to 99% (non-condensing)
- Detectors with camera

- Operating temperature range: -10°C to +50°C*
- Storage temperature range: -20°C to +70°C
- Relative humidity: Up to 99% (non-condensing)

Note: * The detector will turn the camera off if the temperature goes outside this range but fire detection capability is still present when the video is switched off.

4.8 Heat Detectors

4.8.1 The heat detectors shall be capable of detecting rapid rise in temperature and fixed absolute temperatures.

4.8.2 The heat detectors shall meet the requirements of BS EN 54 part 5.

4.8.3 The heat detectors shall be approved and listed by the Loss Prevention Certification Board (LPCB) or Vds.

4.8.4 The heat detectors shall employ two heat sensing elements with different thermal characteristics to provide a rate of rise dependent response.

4.8.5 The temperature sensing elements and circuitry of the heat detectors shall be coated with epoxy resin to provide environmental protection.

part two | specification for an analogue addressable fire system

automatic fire detectors

4.8.6 The heat detectors shall include RFI screening and feed-through connecting components to minimise the effect of radiated and conducted electrical interferences.

4.8.7 The Fire Alarm contractor shall have available the following versions of the heat detectors to meet different applications:

- Digital addressable (adjustable sensitivity)
- Digital addressable (adjustable sensitivity) – intrinsically safe
- Conventional
- Conventional – intrinsically safe

4.8.8 The heat detector shall incorporate an LED, clearly visible from ground level at all angles. The LED's shall pulse to indicate they are communicating and will light permanently when in alarm. For any areas where complete darkness is required, it shall be possible to programme individual detector LED's not to pulse during the quiescent state.

4.9 Linear Heat Detectors

4.9.1 The linear heat detectors shall be capable of detecting fire (or overheat) conditions in confined or polluted areas.

4.9.2 The sensor cable of the linear heat detectors shall be unaffected by dust, moisture or vibration and require little maintenance.

4.9.3 The detectors shall have a calibration switch mounted internally to set the alarm sensitivity threshold.

4.9.4 The detectors shall generate an alarm condition if the pre-determined alarm threshold is exceeded.

4.9.5 The detectors shall generate a fault condition if the sensor cable has an open or short circuit condition present.

4.9.6 The detectors, upon detecting a cable open or short circuit or fault, shall be capable of signalling the condition to the main fire controller.

4.9.7 The linear heat detectors shall meet the requirements of BS EN 54 – 5.

4.9.8 The linear heat detectors shall be approved and listed by the Loss Prevention Certification Board (LPCB) or Vds.

4.9.9 The detectors shall be suitable for use in hazardous areas and have mechanical protection for cables in areas where damage may occur.

part two | specification for an analogue addressable fire system automatic fire detectors

4.9.10 The detectors shall incorporate red Fire and yellow Fault LED's, clearly visible from the outside, to provide indication of alarm condition.

4.10 Beam Smoke Detectors

4.10.1 The beam smoke detectors shall be capable of detecting the presence of smoke in large open-type interiors.

4.10.2 Either point to point or reflective beam smoke detectors will be utilised.

4.10.3 The beam smoke detectors shall project a modulated infra-red light beam from a transmitter unit to a receiver unit. The received signal shall be analysed and, in the event of smoke being present for a pre-determined period, an alarm condition is activated.

4.10.4 The detectors shall be capable of providing cover in open areas up to 100m in length and up to 14m wide, giving an effective protection area of up to 1400sq m.

4.10.5 The fire alarm output of the detectors shall be activated in the event of smoke reducing the signal strength between 40% and 90% for a period of approximately 5 seconds.

4.10.6 In the event of a power failure at the transmitter unit or if the transmitted signal is reduced by more than 90% for a period in excess of 1 second, then a fault alarm condition shall be indicated. This condition shall inhibit the fire alarm until the signal is restored.

4.10.7 The receiver unit of the detectors shall be capable of performing an automatic reset, approximately 5 seconds after a fault is indicated, if the fault is no longer present.

4.10.8 The detectors shall include Automatic Gain Control (AGC) circuitry capable of providing compensation for long-term degradation of signal strength caused by component ageing or build-up of dirt on the optical surfaces of the transmitter and receiver unit lenses.

4.10.9 The beam smoke detectors shall meet the requirements of BS 5839 pt 5.

4.10.10 The beam smoke detectors shall be approved and listed by the Loss Prevention Certification Board (LPCB) or Vds.

4.10.11 The receiver unit of the detectors shall incorporate an alignment/fault lamp, clearly visible from the outside, to provide

part two | specification for an analogue addressable fire system automatic fire detectors

indication of both alignment and fault conditions.

4.11 Aspirating Smoke Detectors

4.11.1 The aspirating smoke detectors shall be capable of detecting the presence of smoke particles in air samples drawn from many different locations.

4.11.2 The aspirating smoke detectors shall provide a continuous analogue profile of ambient air conditions.

4.11.3 The detectors shall be capable of responding to a developing fire situation with multiple staged alarms.

4.11.4 The fire alarm output of the detectors shall be programmable to allow sufficient time for action to be taken; from a detailed investigation of the cause of the alarm to a full-scale evacuation.

4.11.5 The design of the detectors shall be such that they can be integrated with a fire alarm system and guard against specific pieces of equipment, such as computers, equipment racks, power boards and telecommunications switching racks, as well as entire rooms or floors.

4.11.6 The detectors shall include a facility to allow sensitivity threshold adjustments to suit the needs of particular environments.

4.11.7 Each detector shall be capable of monitoring an area up to 2000 sq m using easy to install ABS pipe.

4.11.8 The aspirating smoke detectors shall be approved TO BS 5839 PC20 and listed by the Loss Prevention Certification Board (LPCB).

4.11.9 The detectors shall incorporate an LED indicator, clearly visible from the outside, to provide indication of alarm or fault condition.

4.12 Carbon Monoxide (CO) Fire Detector

4.12.1 The Carbon Monoxide (CO) fire detectors shall be designed to provide early warning of a slow smouldering fire whilst reducing the incidences of false alarms.

4.12.2 The CO detectors shall be approved and listed by the Loss Prevention Certification Board (LPCB).

part two | specification for an analogue addressable fire system automatic fire detectors

4.12.3 The detectors shall have a high tolerance of where they can be sited due to the diffusion nature of the gas.

4.12.4 The CO detectors shall monitor and use rapid changes in temperature to increase the normal sensitivity of the CO sensor to obtain an improved response to fast burning fires where, typically, the levels of CO would be reduced.

4.12.5 The CO detector shall be capable of operating as a single address employing both detection technologies and as a multiple addressed device using 2 addresses. Using 2 addresses, the detector shall be capable of operating as a heat detector and a CO detector simultaneously thus providing alarm verification in a single detector.

4.12.6 The detector shall not be affected by the build up of dust deposits.

4.12.7 The detector shall not be affected by insects.

4.12.8 The sensitivity of the detector shall be able to be adjusted from the control panel.

4.12.9 The detectors shall be designed to have high resistance to contamination and corrosion.

4.12.10 The detectors shall include RFI screening and feed-through connecting components to minimise the effect of radiated and conducted electrical interference.

4.12.11 The Fire Alarm contractor shall have available the following versions of the detector to meet different applications:

- Analogue addressable - adjustable sensitivity
- Conventional - normal sensitivity

4.12.12 The detector shall incorporate an LED, clearly visible from ground level at all angles. The LED's shall pulse to indicate they are communicating and will light permanently when in alarm. For any areas where complete darkness is required, it shall be possible to programme individual detector LED's not to pulse during the quiescent state.

4.13 Remote Indicator Module

4.13.1 The remote indicator module shall provide a remote indication for any conventional or analogue addressable detector that may be located in an enclosed or locked compartment.

4.13.2 The remote indicator module shall be driven directly from its associated local detector.

part two | specification for an analogue addressable fire system automatic fire detectors

4.13.3 The connection to the remote indicator module shall be monitored for open and short-circuits.

4.13.4 Despite being connected to a specific detector, the LED indicator module must be capable of being programmed to respond to any single detector or a group of detectors as required.

part two | specification for an analogue addressable fire system associated ancillary equipment

5 Associated Ancillary Equipment

5.1 General Requirements

5.1.1 The Fire Alarm contractor shall have available the following types of manual call points and line modules for direct connection to the system addressable loops:

- Manual call points for indoor use
- Manual call points for outdoor use
- Conventional detector interface module
- Addressable relay interface module
- High voltage relay module
- Addressable contact monitoring module
- Addressable input / output module
- Addressable door control module
- Addressable sounder driver module
- Addressable loop powered sounder module
- Addressable power supply module
- Line isolator module
- Addressable Loop Powered Sounder / Beacon

- Addressable Loop Powered Sounder Base
- Addressable 4-20mA monitoring module

5.1.2 The Fire Alarm contractor shall have available an intrinsically safe version of the addressable contact monitoring module for connection of 'simple apparatus' such as conventional manual callpoints.

5.1.3 The intrinsically safe device specified in clause 5.1.2 shall be designed to comply with EN50014 and EN50020 and be ATEX certificated by BASEEFA to EEx ia IIC T5. 4.1.15 All equipment connected to the system addressable loops, either directly or via interfaces, shall be proofed against electrical noise, high frequency pulses and electromagnetic influences from other equipment.

5.2 Addressable Manual Call Points

5.2.1 The addressable manual call points shall monitor and signal to the control and indicating equipment the status of a switch operated by a 'break glass' assembly.

part two | specification for an analogue addressable fire system associated ancillary equipment

5.2.2 The addressable manual call point shall meet the requirements of BS EN 54: Part 11

5.2.3 The addressable call points shall be capable of operating by means of thumb pressure and not require a hammer.

5.2.4 The addressable call points shall be capable of being mounted in weather-proof enclosures affording protection to IP65.

5.2.5 The addressable call points shall incorporate a mechanism to interrupt the normal addressable loop scan to provide an alarm response within less than 3 seconds.

5.2.6 The addressable call points shall be field programmable to trigger either an alert or an evacuate response from the control and indicating equipment

5.2.7 The addressable call points shall be capable of being tested using a special 'key' without the need for breaking the glass.

5.2.8 The addressable call points shall provide an integral red LED to indicate activation.

5.3 Conventional Detector Interface Module (Including 4-20mA Monitoring)

5.3.1 The conventional detector interface module shall monitor and signal to the control and indicating equipment the status of up to two circuits each of 20 conventional detectors and manual call points if supplied from an external 24Vdc, or 6 conventional detectors and manual call points if deriving its operating power from the addressable loop.

5.3.2 The conventional detector interface module shall be able to distinguish between automatic conventional detectors and manual callpoints on the same circuit for the purposes of alarms and isolations.

5.3.3 The conventional detector interface module shall be able to signal alarm, open-circuit fault, short-circuit fault and power supply fault status.

5.3.4 The conventional detector interface module shall be capable of monitoring automatic detectors and manual call points from a range of existing conventional systems.

5.3.5 The conventional detector interface module shall operate such that remo-

part two | specification for an analogue addressable fire system associated ancillary equipment

val of an automatic conventional detector from its base shall not effect the operation of any manual callpoint.

5.3.6 The conventional detector interface module shall incorporate an integral line isolator.

5.3.7 The conventional detector interface module shall provide integral red LED indication when in the alarm state and amber LED indication when the on-board line isolation has operated.

5.3.8 The conventional detector interface module shall be capable monitoring two 4-20mA inputs, sink or source, for the purposes of interfacing proprietary 4-20mA devices e.g. gas detectors.

5.3.9 The conventional detector interface module shall be capable of monitoring ATEX approved intrinsically safe conventional automatic detectors and manual callpoints via external galvanic isolation.

5.4 Addressable Relay Output Module

5.4.1 The addressable relay output module shall provide a volt free changeover relay contact operated by command from the control and indicating equipment

5.4.2 The contacts of the addressable relay output module shall be rated at a minimum of 2 Amps at 24Vdc.

5.4.3 The addressable relay output module shall monitor the relay coil for open-circuit and transmit the fault signal to the control and indicating equipment.

5.4.4 The addressable relay output module shall be capable of deriving its operating power from the addressable loop.

5.4.5 The addressable relay output module shall provide a red LED indication that the relay has operated.

5.5 Addressable Contact Monitoring Module

5.5.1 The addressable contact monitoring module shall provide monitoring of the status of switched input signals from either normally open or normally closed contacts.

5.5.2 The addressable contact monitoring module shall provide a red LED indication when the contact has operated.

5.5.3 The addressable contact monitor module shall be capable of deriving its power directly from the addressable loop.

part two | specification for an analogue addressable fire system associated ancillary equipment

5.6 Addressable Sounder Driver Module

5.6.2 The output of the addressable sounder driver module shall be rated at 500mA.

5.6.3 The addressable sounder driver module shall be capable of operating the sounders in a pulsing or continuous mode as determined by the control and indicating equipment.

5.6.4 The addressable sounder driver module shall provide the facility to monitor the wiring to the sounders for open or short-circuit and transmit the necessary fault signal to the control and indicating equipment.

5.6.5 The addressable sounder driver module shall provide the facility to monitor for failure of the power supply for the sounders and transmit the necessary fault signal to the control and indicating equipment.

5.6.6 The addressable sounder driver module shall provide a red LED indication that the sounder circuit has been actuated.

5.7 Loop Powered Addressable Sounder Driver Module

5.7.1 The loop powered addressable sounder driver module shall comply with all the requirements listed in section 5.5.

5.7.2 The loop powered addressable sounder driver module shall be capable of deriving its power directly from the addressable loop.

5.7.3 The loop powered addressable sounder driver module shall be capable of providing 24Vdc up to a maximum of 75mA.

5.8 Sounder Booster Module

5.8.1 The sounder booster module shall be capable of monitoring and driving a heavy duty circuit of sounders up to 15 Amps.

5.8.2 The sounder booster module shall be capable of interfacing either to the common sounder outputs of the control and indicating equipment or to the output of the addressable sounder driver module.

5.8.3 The sounder booster module shall be designed to maintain the monitoring of the sounder circuit and transmit a fault

part two | specification for an analogue addressable fire system associated ancillary equipment

signal either via the addressable sounder driver module or directly to the control and indicating equipment.

5.9 Addressable Power Supply Module

5.9.1 The addressable power supply module shall be capable of supplying up to 24Vdc, 3 Amps of power to local sounder circuits and ancillary equipment.

5.9.2 The addressable power supply module shall derive its power from the 115/240Vac mains supply.

5.9.3 The addressable power supply module shall be able to contain and maintain in a charged state a 24V battery set of up to 15Ah capacity.

5.9.4 The addressable module shall monitor the mains power supply and the battery and transmit a fault signal as appropriate to the control and indicating equipment.

5.10 Line Isolator Module

5.10.1 Line isolation shall be by the use of either separate modules, line isolator detector bases or line isolation built in to ancillary modules.

5.10.2 The line isolator module shall provide protection on the addressable loop by automatically disconnecting the section of wiring where a short-circuit has occurred.

5.10.3 The line isolator module shall derive power directly from the addressable loop.

5.10.4 The line isolator module shall provide an LED indication that the module has tripped.

5.11 Door Control Module

5.11.1 The door control module shall comply with the requirements of BS7273-4:2007 as a category A actuator. The module must, therefore, be fail safe in the following conditions:

- removal of a detector that will effect the correct operation of the door control module
- isolation of a detector that will effect the correct operation of the door control module
- isolation of the door control module
- an open or short circuit on the cabling that forms part of the critical signal path (eg. the addressable loop)

part two | specification for an analogue addressable fire system associated ancillary equipment

5.11.2 The door control module shall provide an output required to control a hold open fire door device, an electromagnetic release on a means of escape, or a sliding door on a means of escape.

5.11.3 The door control module shall also provide a programmable input that could be used to either monitor an emergency breakglass callpoint that will activate the door control module or to monitor the closure of the door. The module shall, however, take only one address on the addressable loop.

5.11.4 The door control module shall be fully addressable and provide one volt-free changeover relay contact rated at 24Vdc @ 2 Amps.

5.11.5 The door control module shall incorporate an integral line isolator.

5.11.6 The changeover relay contact of the door control module shall be monitored and controlled by commands signalled from the fire alarm system control panel via the addressable loop.

5.11.7 The module shall derive its power directly from the addressable loop.

5.11.8 The door control module shall have a red LED, clearly visible on the fascia panel of the unit, to provide an indication of relay operation.

5.12 Multiple Input / Output Module

5.12.1 The multiple input / output module shall provide all 3 inputs and 4 outputs to interface, for example, individual shop units with a landlords site-wide monitoring system.

5.12.2 The multiple input / output module shall be fully addressable and provide 2 volt-free changeover relay contacts rated 24Vdc @ 2A and 4 outputs to operate an external high voltage relay interface rated at 240Vac @ 10A.

5.12.3 The changeover relay contacts of the multiple input / output module shall be monitored and controlled by commands signalled from the monitoring system control panel via the addressable loop.

5.12.4 The multiple input / output module shall be capable of monitoring multiple external relay contacts.

5.12.5 The module shall derive its power directly from the addressable loop.

part two | specification for an analogue addressable fire system associated ancillary equipment

5.13 Single Input / Output Module

5.13.1 The single input / output module shall provide an input and an output. The module shall, however, take only one address on the addressable loop.

5.13.2 The operation of the input and the output shall be independent (ie. the output must not have to follow the input).

5.13.2 The single input / output module shall be fully addressable and provide a volt-free changeover relay contacts rated 24Vdc @ 2A.

5.13.3 The changeover relay contacts of the single input / output module shall be monitored and controlled by commands signalled from the monitoring system control panel via the addressable loop.

5.13.4 The single input / output module shall be capable of monitoring a single external relay contact.

5.13.5 The module shall derive its power directly from the addressable loop.

5.14 Loop Powered Beam Detector Module

5.14.1 The loop powered beam detector module shall provide power to, and monitor the fire and fault outputs of, infra red optical beam detection.

5.14.2 The loop powered beam detector module shall derive its power directly from the addressable loop.

5.14.3 The loop powered beam detector module shall be capable of powered and monitoring reflective and point to point beam detection.

5.14.4 The loop powered beam detector module shall be capable of monitoring multiple external relay contacts.

5.14.5 The loop powered beam detector module shall have a red LED, clearly visible on the fascia panel of the unit, to provide an indication of relay operation.

5.15 Addressable Loop Powered Sounder / Beacon

5.15.1 The loop powered sounder shall be capable of producing a sound output of 103dB at 1m.

part two | specification for an analogue addressable fire system associated ancillary equipment

5.15.2 The loop powered sounder shall have the option of an integral LED beacon.

5.15.3 The loop powered sounder shall have two volume settings, 16 selectable tones and two flash rates (for the LED beacon).

5.15.4 The volume and the tone settings shall be configured by software during system configuration and commissioning. The facility to change the volume and tone settings shall not be available in the sounder.

5.15.5 An IP65 weatherproof version of the sounder and sounder beacon shall be available.

5.15.6 The internal sounders and sounder beacons shall be available in red or white.

5.15.7 The loop powered sounder/beacon shall incorporate an integral line isolator.

5.15.8 The loop powered sounder shall be self monitoring such that if the sounder fails to operate during a test or genuine fire activation, an appropriate fault message is displayed on the control and indicating equipment.

5.15.9 The loop powered sounder/beacon shall derive its power directly from the addressable loop.

5.16 Addressable Loop Powered Sounder/ Beacon Base

5.16.1 The loop powered sounder base shall have a volume range between 68dB and 100dB at 1m and 8 selectable tones.

5.16.2 The loop powered sounder base shall have a volume range between 60dB and 90dB at 1m.

5.16.3 The loop powered sounder base shall have the option of an integral LED beacon which shall be visible from 360°.

5.16.4 The loop powered sounder/beacon base shall have four volume settings, 15 selectable tones and two flash rates (for the LED beacon).

5.16.5 The volume, tone settings and flash rate shall be configured by software during system configuration and commissioning. The facility to change the volume and tone settings shall not be available in the sounder.

part two | specification for an analogue addressable fire system associated ancillary equipment

5.16.6 The loop powered sounder/ beacon base shall incorporate an integral line isolator.

5.16.7 The loop powered sounder base shall be self monitoring such that if the sounder fails to operate during a test or genuine fire activation, an appropriate fault message is displayed on the control and indicating equipment.

5.16.8 The loop powered sounder/ beacon base shall derive its power directly from the addressable loop.

5.16.9 The loop powered sounder/ beacon base shall have independent addresses for the sounder and beacon such that they can be individually controlled and isolated by the control and indicating equipment.

part two | specification for an analogue addressable fire system cables

6 Cables

6.1 Type

6.1.1 Cables used for all parts of the critical signal paths shall comprise one of the following:

Mineral insulated copper sheathed cables, with an overall polymeric covering, conforming to BS EN 60702-1, with terminations conforming to BS EN 60702-2

Cables that conform to BS 7629

Cables that conform to BS 7846

Cables rated at 300/500V (or greater) that provide the same degree of safety to that afforded by compliance with BS 7629

6.1.2 Standard fire resisting cables should meet the PH 30 classification when tested in accordance with EN 50200 and maintain circuit integrity if exposed to the following test:

A sample of the cable is simultaneously exposed to flame at a temperature of 830 degrees C and mechanical shock for 15

minutes, followed by simultaneous exposure to water spray and mechanical shock for a further 15 minutes.

6.1.3 Enhanced fire resisting cables should meet with the PH120 classification when tested in accordance with EN 50200 and maintain circuit integrity if exposed to the following test:

A sample of the cable is simultaneously exposed to flame at a temperature of 930 degrees C and mechanical shock for 60 minutes, followed by simultaneous exposure to water spray and mechanical shock for a further 60 minutes.

6.2 Containment

6.2.1 Cable support methods must withstand a similar temperature and duration as that of the cable used such that circuit integrity is not reduced and adequate support is maintained.

6.2.2 Cables should be installed without external joints where possible and other than joints within system components, should be enclosed within junction boxes, labelled 'FIRE ALARM'.

part two | specification for an analogue addressable fire system cables

6.2.3 Other than joints within system components terminals used to join cables should be constructed of materials that will withstand a similar temperature and duration to that of the cable.

6.2.4 Any conduit used should conform to the relevant parts of BS EN 50086.

6.2.5 Any non metallic trunking used in the system should conform to BS 4678 part 4.

6.2.6 The preferred colour of the cable shall be red and shall be a single, common colour throughout.

part two | specification for an analogue addressable fire system networking and graphics

7 Networking and Graphics

7.1 Sub Panels

7.1.1 The system must be capable of supporting up to 99 sub panels / graphic stations and provide a seamless, integrated graphical mimic with full alarm management and panel control capability.

7.1.2 The network must be a true peer to peer network whereby the failure of a single node will not affect the operation of any other node on the network.

7.1.3 The network must be LPCB approved.

7.1.4 The network must be capable of being wired in MICC cable with up to 1000m between nodes.

7.1.5 Nodes must be peer to peer with no master panel.

7.1.6 The network must be capable of supporting a maximum distance of 4000m between nodes using cables other than MICC.

7.2 Graphical User Interface

7.2.1 The system must be designed for use with a touch screen or mouse and must not require the use of a QWERTY keyboard.

7.2.2 The Fire Alarm contractor shall be responsible for the design, supply, installation, commissioning configuration and servicing of a graphical user interface for the fire detection system.

7.2.3 The graphical user interface software shall be designed, written and owned by the company configuring and commissioning the fire detection and alarm system.

7.2.4 The software shall control the operations, functions and display of the graphics system and provide for automatic boot up and run from the hard disk drive of the computer. A software security facility shall be provided to prevent unauthorised access to the operating system, drives, or configuration menus. The software shall include an automatic database rebuild utility to aid system recovery in the event of unexpected system failure.

part two | specification for an analogue addressable fire system networking and graphics

7.2.5 All project specific actuating device programming shall be capable of being carried out on site via password access.

7.2.6 The operating system that the graphical user interface has been designed to work on and has been tested on shall be Windows® 2000 or Windows XP Professional.

7.2.7 The graphical user interface shall provide the means for annunciation, status display, and control of the fire detection system.

7.2.8 The graphical user interface software shall be a true Client / Server application and enable any number of clients to access one central configuration database.

7.2.9 The system shall have the capacity to sequence up to 2000 simultaneous alarms, faults, and circuit/point, isolate events. The system shall be capable of automatically displaying a device specific custom message of 70 characters for each actuating device connected to the fire alarm control panel.

7.2.10 When an event is registered at any fire alarm control panel the graphics system shall display the first screen image for the first actuated device. The option

shall be available to display the first screen image for the most recent fire alarm if required. The system shall be capable of zooming in for further information up to ten (10) times if required. At all times when in the alarm or fault mode the fire control panel status i.e. number of current alarms and/or faults is to be displayed on the graphics screen.

7.2.11 It shall be possible to easily and quickly hand off whole sections of the fire detection network for a set period of time, for maintenance purposes. Events generated by devices that have been handed off shall not be alerted to the operator. However, these events shall be logged in the same manner as all other events and actuations. Once initiated, the operator shall have the capacity to override the handoff manually at any time.

7.2.12 All security administration and operator accounts shall be administered centrally through the client's common database.

7.2.13 The graphical user interface shall have a minimum of 8 operator access levels to prevent unauthorised access into specific areas of the system.

part two | specification for an analogue addressable fire system networking and graphics

7.2.14 The graphical user interface shall support a network of 99 control panels / graphical user interfaces with 1000 addressable points connected to each control panel.

7.2.15 Multiple workstations shall be configurable for either specific functions or redundant operation.

7.2.16 Response buttons with recognizable icons shall provide control switches specific to any operation being performed.

7.2.17 The graphical user interface shall provide operator control via a mouse, keyboard or touch-screen with full multimedia compatibility.

7.2.18 The system should support the connection of a separate monitor to enable Graphics and Text alarms to be displayed on separate screens if required.

7.2.19 The graphical user interface shall display the precise location of events and give instructions on what emergency action should be taken using a combination of symbols, floor plans, pictures text, audio and video to communicate.

7.2.20 The graphical user interface configuration software shall support all stan-

dard PC picture file types (i.e. GIF, JPG, BMP), AutoCAD® & Vector file types.

7.2.21 In order to assist operators and response teams the graphical user interface shall be capable of printing maps and instructions on local or networked printers.

7.2.22 The graphical user interface shall store a history log of all events centrally. The graphics system shall monitor all alarms, Circuit/Point activations, faults, Ancillary and Isolate events detected by any fire alarm control panel and provide disk based log files of these events. These logs may be enabled, disabled, or cleared with password access. These log files are to be continually appended with events so as to provide complete historical information of all alarms and faults. This log information is not to be lost upon power failure or fire alarm control panel reset. The history log shall be recallable or printable by event type, date, time, date range, time range, device address, address range, device type, device location or text description.

7.2.23 Streaming video feeds from on-site IP based CCTV cameras shall be able to be displayed on the graphical system. The video feeds shall display automatically on annunciation of a relevant alarm. The

part two | specification for an analogue addressable fire system networking and graphics

operator shall also be able to view the video feeds manually.

7.2.24 Events handled by the graphical user interface shall be either accepted individually or universally as required.

7.2.25 Critical fire panel commands for example: isolate, de-isolate, entered via the graphical user interface shall be able to accept bespoke alphanumeric input from the operator that will be stored with the event in the event history log.

7.2.26 The event banner shall be easily configured to suit the customers need to include alarm, fault, isolate, evacuate etc status and control as necessary.

7.2.27 System configuration shall be menu driven and capable of being operated by a person with no previous computer programming experience. The configured devices shall be placed on the maps using a simple 'drag and drop' facility.

part two | specification for an analogue addressable fire system documentation

8 Documentation

8.1 Tender Documentation

8.1.1 At the time of tendering, the Fire Alarm contractor shall fully and accurately describe the proposed fire detection and alarm system and its design concepts.

8.1.2 The Fire Alarm contractor shall provide a complete set of layout drawings and specifications describing all aspects of the system, including:

1. Detailed component and equipment list with model and manufacturers part numbers.
2. Product sheets for each item of equipment.
3. Theory of Operations with description of system functions.
4. Written confirmation that a manufacturer trained representative will:
 - a) provide on-site supervision during system installation
 - b) perform all final testing and commissioning of the installed system
 - c) instruct operating personnel on all system operations.

8.1.3 The Fire Alarm contractor shall provide a schedule showing the times required to design, build, install, test and commission the system. The schedule shall also include any special requirements, such as additional training for operating personnel, etc.

8.2 Contract Documentation

8.2.1 The Fire Alarm contractor shall provide a complete set of documents describing the system and its design concepts, installation, final testing, commissioning, and required operating and maintenance procedures.

8.2.2 As a minimum, the following documentation shall be provided for the system:

1. System description.
2. Checklist of equipment and components.
3. Installation instructions.
4. Equipment connection diagrams showing wiring detail of Addressable Device positions with addresses.
5. Standby battery calculations showing system power requirements and formulas used to calculate specified power.

part two | specification for an analogue addressable fire system documentation

6. Final testing instructions.
7. Commissioning instructions.
8. BAFE certification documents.
9. Log book.
10. System operating instructions.
11. Routine maintenance instructions and schedules.
12. Remote monitoring link description and operating instructions (if this option is being provided).

1. Fire controller
2. Detectors
3. Call points
4. Sounders
5. Ancillary devices
6. Remote monitoring link (if this option is being provided).

8.2.5 The date for submission of all documentation shall be in accordance with the schedule provided by the Fire Alarm contractor and as agreed with the client.

8.2.3 As a minimum, the following drawings shall be provided for the system:

1. System schematic diagram.
2. Cabling and wiring diagram.
3. Detailed equipment connection diagrams.
4. Building plan showing zoning and location of fire controller, detectors, call points, sounders and ancillary devices.

8.2.4 The Fire Alarm contractor shall provide a complete set of system operating and maintenance manuals for the following:

part two | specification for an analogue addressable fire system installation

9 Installation

9.1 General

9.1.1 Correct installation, combined with the use of high quality equipment, components and cabling, ensures that the fire detection and alarm system shall operate as designed and provide many years of trouble-free service.

9.1.2 The Fire Alarm contractor shall install the alarm system in accordance with the documented installation instructions.

9.1.3 The Fire Alarm contractor shall provide all relevant installation documentation required for each component of the system.

9.1.4 Installation of the system shall be in accordance with the recommendations set out in BS 5839-1:2002 (Fire detection and fire alarm systems for buildings - Code of practice for system design, installation, commissioning and maintenance) and BS 7671 (Requirements for Electrical Installations - IEE Wiring Regulations, Seventeenth Edition).

9.1.5 The Fire Alarm contractor shall be responsible for the correct siting of all equipment and components of the system in

accordance with previously agreed plans and drawings.

9.1.6 All cabling and wiring shall be tested before they are connected to the fire controller and its associated devices.

WARNING If the tests are carried out after the cables and wires have been connected to the controller and its devices, components within the controller and the devices will be damaged by high voltages used during testing.

9.2 Materials

9.2.1 All cabling and wiring to be used in the system shall be fire resistant and approved to BSI and LPCB specifications for use in fire detection and alarm systems.

9.2.2 Wiring used for driving devices requiring high currents (e.g. bells, etc.) shall limit the voltage drop to less than 10% of the nominal operating voltage.

9.2.3 Cables used for the transmission of system data and alarm signals shall be in accordance with the types recommended by the manufacturer of the fire alarm system, with attention paid to any particular (i.e. enhanced) cable requirements that may result from a risk assessment.

part two | specification for an analogue addressable fire system installation

9.2.4 The ends of all cables shall be sealed by means of proprietary seals and associated glands. No heat shall be applied to any seal or termination. Cable tails shall be insulated by means of blank PVC sleeving anchored and sealed into the seal.

9.2.5 Where protection of the cable glands is required or terminations are on display, the glands shall be enclosed in red coloured shrouds of the appropriate British Standard colour.

9.2.6 All cables to brick/concrete shall be securely fixed by means of copper saddles sheathed with red PVC. These saddles shall be provided near bends and on straight runs at intervals no greater than recommended in the British Standards or by the manufacturer.

9.2.7 Where multiple cables are to be attached to a wall or soffit, copper saddles shall enclose all cables and shall be secured by means of suitable masonry plugs and two round head plated woodscrews.

9.2.8 Where multiple cables are to be attached to the top of horizontal trays they shall be neatly run and securely fixed at suitable intervals. Copper cable fixings shall be used.

9.2.9 At detector and sounder locations, cables shall be terminated in approved black enamelled/ galvanised BESA or MI Clamp type junction boxes. All other devices forming part of the system shall utilise dedicated/custom back boxes.

9.3 Installation of Detectors

9.3.1 All detectors (and bases) shall be installed in accordance with guidelines set out in BS 5839-12002, BS 7671 and the installation instructions provided by the manufacturer.

9.3.2 All detectors shall be installed in the exact locations specified in the design drawings; thus providing the best possible protection.

9.3.3 The type of detector installed in each particular location shall be the type specified in the design drawings.

9.3.4 All detector bases shall be securely fixed to BESA boxes and allow for easy fitting and removal of detectors.

9.3.5 Cable and wire entries to detector bases shall be fitted with grommets to prevent possible damage to the insulation.

part two | specification for an analogue addressable fire system installation

9.3.6 Cable and wire strain relief clamps shall be provided at all entries to detector bases.

9.3.7 Cable entries of detector bases used in environments with abnormal atmospheric or operating conditions shall be appropriately sealed to prevent ingress of dust, water, moisture or other such contaminants.

9.4 Installation of Control Devices

9.4.1 All control devices (e.g. call points, sounders, interface modules, etc.) shall be installed in accordance with the guidelines set out in BS 5839-1:2002, BS 7671 and the installation instructions provided by the manufacturer.

9.4.2 All control devices and associated modules shall be installed in the exact locations specified in the design drawings.

9.4.3 The type of control device installed in each particular location shall be the type specified in the design drawings.

9.4.4 All control devices and associated modules shall be securely fixed and, if required, marked with appropriate notices or warning signs as applicable.

9.4.5 Cable and wire entries to all control devices and associated modules shall be fitted with grommets or glands so as to prevent possible damage to the insulation.

9.4.6 Cable and wire strain relief clamps shall be provided at entries to control devices and associated modules as required.

9.4.7 Cable entries of control devices and associated modules used in environments with abnormal atmospheric or operating conditions shall be appropriately sealed to prevent ingress of dust, water, moisture or other such contaminants.

9.5 Installation of Fire Controller Equipment

9.5.1 The fire controller equipment shall be installed in accordance with the guidelines set out in BS 5839-1 2002, BS 7671 and the installation instructions provided by the manufacturer.

9.5.2 The fire controller and its associated component parts shall be installed in the location specified in the design drawings.

9.5.3 The type of fire controller and its associated component parts installed shall be the type specified in the design drawings.

part two | specification for an analogue addressable fire system installation

9.5.4 The fire controller equipment shall be securely fixed and, if required, marked with appropriate notices or warning signs as applicable.

9.5.5 Cable and wire entries to the fire controller and associated devices shall be fitted with grommets or glands to prevent possible damage to the insulation.

9.5.6 Cable and wire strain relief clamps shall be provided at entries to fire controller and associated devices as required.

9.5.7 The fire alarm system mains power connections to the fire controller equipment shall be accordance with the guidelines set out in the relevant British Standards and the installation instructions provided by the manufacturer.

9.5.8 The fire alarm system mains power isolating switch shall be coloured red and clearly labelled 'FIRE ALARM: DO NOT SWITCH OFF'.

9.5.9 Each circuit of the system shall be connected to the fire controller via associated fuse or circuit breaker devices located within the fire controller unit.

9.5.10 All cables from the fire controller equipment to the detection and alarm devices shall be clearly labelled as part of the fire detection and alarm system.

part two | specification for an analogue addressable fire system commissioning

10 Commissioning

10.1 General

10.1.1 Both the installation (see Section 7) and the commissioning activities shall be undertaken as a single continuous operation.

10.1.2 Upon completion of the installation activity, the Fire Alarm contractor shall Test, Start-up, Commission and Handover the system to the client.

10.1.3 The fire system shall have the capability of demonstrating and proving the job specific cause and effect requirements without the need to connect the field devices. This must be possible using the control and indicating equipment and a computer only. It must be possible to produce a log of the test procedure for inclusion in the hand over documentation, if required.

10.1.4 The Fire Alarm contractor shall make use of the following documents to record test results and details of commissioning tests:

- Cable Test Sheets
- Installation Check Report
- System Layout Drawing(s)
- System Schematic Diagram(s)

10.1.5 In addition, Point Description Sheets which are used to configure the text descriptions displayed at the controller must be returned to the Fire Alarm contractor 21 days prior to the date agreed for commencement of commissioning. Copies of Point Description Sheets are provided to the client upon receipt of the order for the fire system.

10.2 Testing and Start-up

10.2.1 The Fire Alarm contractor shall be responsible for inspecting and testing the complete system, including:

1. Detectors
2. Call Points
3. Sounders
4. Ancillary Devices
5. Fire Controller Equipment and Associated Devices
6. Auxiliary Equipment (e.g. Plant Interface Module, etc.)
7. Operating and Control Software.

10.2.2 The fire controller and associated devices and modules shall be tested in accordance with the guidelines set out in BS 5839 - 1: 2002 and the testing instructions provided by the manufacturer.

part two | specification for an analogue addressable fire system commissioning

10.2.3 The Fire Alarm contractor shall start up and operate the system for a trial period to ensure that it operates correctly.

10.2.4 The Fire Alarm contractor shall test all functions of the system, including the software, to ensure that it operates in accordance with the requirements of the design specification and relevant standards.

10.2.5 The Fire Alarm contractor shall undertake audibility tests during which the sounders may be operated continuously over a period of two hours. (Should the client require these tests to be carried out at a separate visit, or out of normal working hours, this can be arranged at additional cost).

10.3 Commissioning

10.3.1 Commissioning of the system shall constitute practical completion.

10.3.2 Following the satisfactory completion of installation, testing and start up, the Fire Alarm contractor shall demonstrate to the client that the system successfully performs all of the functions set out in the design specification.

10.3.3 The Fire Alarm contractor shall provide the client with an agreed quanti-

ty of spare parts testing equipment and consumables which are to be used during routine maintenance and testing of the system.

10.3.4 The Fire Alarm contractor shall provide a client appointed fire system supervisor with on-site training in the use, operation and maintenance of the system and explain the procedures to be followed in the event of fire and false alarms. The system supervisor shall also be shown how to carry out routine maintenance and testing procedures, and how to keep the Log Book. (also see Section 9).

10.3.5 The Fire Alarm contractor shall prepare a report detailing all tests performed during installation and commissioning of the system. The report shall include the results of the tests and details of any specific settings or adjustments made. Any outstanding tasks or activities which are to be completed at another time shall also be included in the report.

10.3.6 The Fire Alarm contractor shall present an Acceptance Certificate for signature by the client.

part two | specification for an analogue addressable fire system commissioning

10.4 Handover

10.4.1 The Fire Alarm contractor, upon completion of the commissioning activity, shall hand over the system to the client.

10.4.2 At the time of hand over, the Fire Alarm contractor shall provide the client with the following documentation:

1. Copy of detailed report (see clause 8.3.5 above)
2. Component and equipment list
3. Product description sheets
4. System design specification
5. System design drawing(s)
6. System schematic diagram(s)
7. System operating and service manuals
8. Certificate of commissioning
9. Fire system users handbook, containing log book, routine maintenance instructions and schedules
10. Remote monitoring link description and operating instructions (if this option was provided).

part two | specification for an analogue addressable fire system training

11 Training

11.1 General

11.1.1 The Fire Alarm contractor shall provide the client with details of the training required by personnel to operate and maintain the fire detection and alarm system.

11.1.2 This training shall also be available in the form of an interactive CD ROM.

11.1.3 The Fire Alarm contractor shall provide two levels of training:

- System Supervisor Training
- Other Staff Training

11.1.4 The Fire Alarm contractor and the client shall jointly agree the number of staff to attend the training courses.

11.2 System Supervisor Training

11.2.1 System supervisor training shall include technical training sessions provided at the Fire Alarm contractor's premises and/or on-site training given during installation and commissioning of the system.

11.2.2 System supervisor training shall be given by an experienced and compe-

tent engineer familiar with the fire system being installed.

11.2.3 The scope of training provided shall depend on the type, size and complexity of the system.

11.2.4 The Fire Alarm contractor shall initially provide technical training in all aspects of the system. The trainee shall then be given full instructions in the use, operation and maintenance of the system. This shall include instruction in the procedures to be followed in the event of fire and false alarms, routine maintenance and testing procedures, and how to keep the Log Book.

11.3 Other Staff Training

11.3.1 Other staff training shall include training sessions provided on-site after hand over of the system.

11.3.2 The training sessions shall be given by an experienced and competent engineer familiar with the fire system installed.

11.3.3 The scope of training provided shall include full operating instructions in the use of the fire system. This shall include instruction in the procedures to be followed in the event of fire and false alarms.

part two | specification for an analogue addressable fire system maintenance

12 Maintenance

12.1 General

12.1.1 According to the recommendations in BS 5839-1:2002 fire systems should be regularly maintained under a maintenance agreement.

12.1.2 Fire and planning authorities, and in certain cases insurers, have powers to check that fire systems are maintained. Failure to maintain the fire detection and alarm system could contribute to death or injury in the event of fire. It is a requirement of the Fire Safety Order (FSO), that all fire detection and alarm systems are regularly maintained.

12.1.3 The client shall be responsible for ensuring that daily, weekly and monthly routine maintenance is carried out in accordance with the recommendations set out in BS 5839-1:2002 and the service and maintenance instructions provided by the Fire Alarm contractor or manufacturer.

12.1.4 The Fire Alarm contractor shall provide detailed information about the maintenance services which can be provided after hand over of the system.

12.1.5 If requested, the Fire Alarm contractor shall prepare and submit a draft maintenance contract for consideration by the client.

12.1.6 The draft contract shall include complete details of all materials and labour required to maintain the system in correct working order. It shall also include details of the testing procedures which will be carried out and specify the proposed number of visits per year.

12.1.7 The Fire Alarm contractor shall be able to offer a 24 hour 365 day service call-out facility, with a maximum response time of 8 hours.

12.2 System Spares

12.2.1 The Fire Alarm contractor shall provide a detailed list of the system spares which should be kept on-site for maintenance of the system.

12.2.2 Although the quantity of each item required is dependent upon the type and size of installation, the system spares which should be considered for inclusion in the list are as follows:

- Heat Detectors
- Smoke Detectors
- Flame Detectors

part two | specification for an analogue addressable fire system maintenance

- CO Detectors
- Call Points
- Sounders
- Beacons
- Door Retention Units
- Fuses
- Circuit Breakers

12.2.3 The draft maintenance contract shall also include details of the system spares which are to be kept on-site for maintenance of the system.

12.2.4 The Fire Alarm contractor shall guarantee the availability of all system spares for a period of not less than ten years.

12.3 System Test Equipment

12.3.1 The Fire Alarm contractor shall provide a detailed list of the system test equipment and consumables required on-site to maintain the system in perfect working order.

12.3.2 As the quantity of each item required is dependent upon the type and size of installation, the system test equipment and consumables which should be considered for inclusion in the list are as follows:

- Detector Head Removal Tool
- Call Point Testing Tool
- Detector Test Smoke Canister
- Detector Test Adaptor
- Aerosol Dispensing Tube
- Extension Tubes
- Spare Log Book

12.3.3 The draft maintenance contract shall also include details of the system test equipment and consumables which are to be kept on-site for routine maintenance and testing of the system.

12.3.4 The Fire Alarm contractor shall guarantee the availability of all system test equipment and consumables for a period of not less than ten years.

part two | specification for an analogue addressable fire system

appendix

Appendix A

Short Form Specification – Key Points

Control & indicating Equipment

- The system shall allow the following functions to be carried out without the need for a computer, software or the attendance of an engineer.
 - change panel text
 - change zone text
 - change sector text (for networked systems)
 - change individual point text
 - add addressable devices
 - delete addressable devices
 - modify addressable devices
 - change individual point addresses
- The panel shall be capable of monitoring 250 addressable devices per loop and 240 zones.
- The system shall have a clear, easy to understand LCD display with a minimum of 16 lines.
- High level access to the system shall be passcode protected.

Automatic Detectors

- The detection shall be capable of operating as a single address or a multiple address device.
- Detection shall have the ability to work as fire / smoke detectors and heat detectors simultaneously.
- Toxic gas detection approved to EN50291 shall be included.
- Remote LED indication shall be capable of responding to a single detector or a group of detectors.
- Hazardous area detection must be approved to ATEX for both gas and dust.
- Addressable aspirating detection shall be available.

Associated Ancillary Equipment

- Any door release equipment shall comply with the requirements of BS 7273 Pt 4:2007.
- Loop powered fire alarm sounders shall be self monitoring.

part two | specification for an analogue addressable fire system

appendix

- Loop powered sounder bases shall be capable of producing 100dB(A) at 1m.
- There shall be the ability to monitor any 4 to 20mA device directly from the addressable loop.
- The tone and volume of loop powered sounders shall be set at the control panel.
- The system must have the ability to provide wall mounted addressable beacons which can be easily seen by the hearing impaired.
- The network shall be capable of operating over copper, fibre and TCP/IP.
- The network shall not rely upon a single network node.

Training

- Training must be available in the form of an interactive CD ROM.

Networking & Graphics

- The system shall be a true client server application.
- The system shall be easy to reconfigure and modify.
- The system shall be capable of displaying text on one screen and graphics on another.
- The system shall be capable of interfacing with other services (i.e. CCTV).
- The network shall be capable of supporting 99 panels / graphic stations.

